

DTS(G)L-6, DTS(G)F-6 SERIES

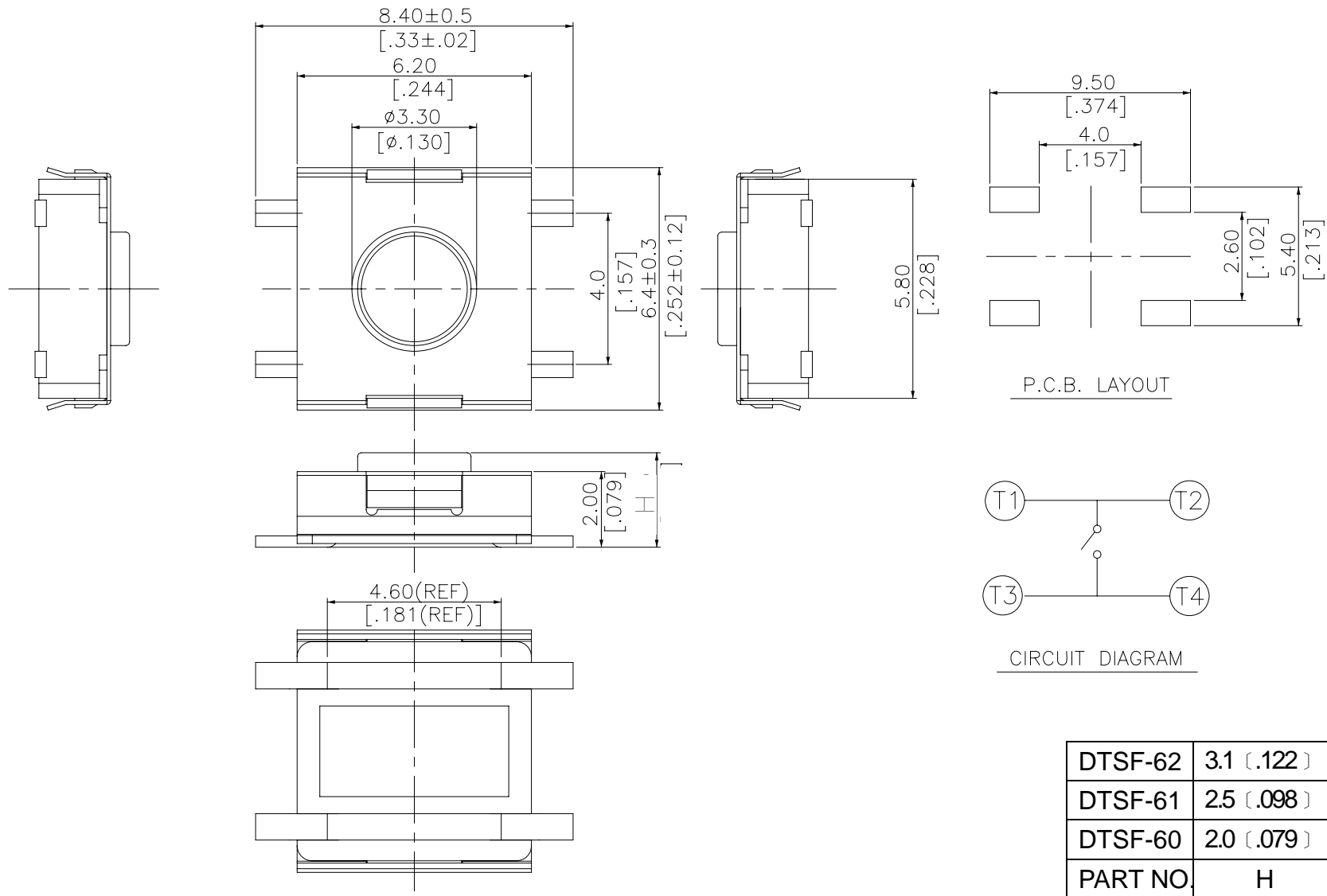

DIMENSIONS

DTSF-6



General Tolerance : ±0.2mm

DTSGF-6

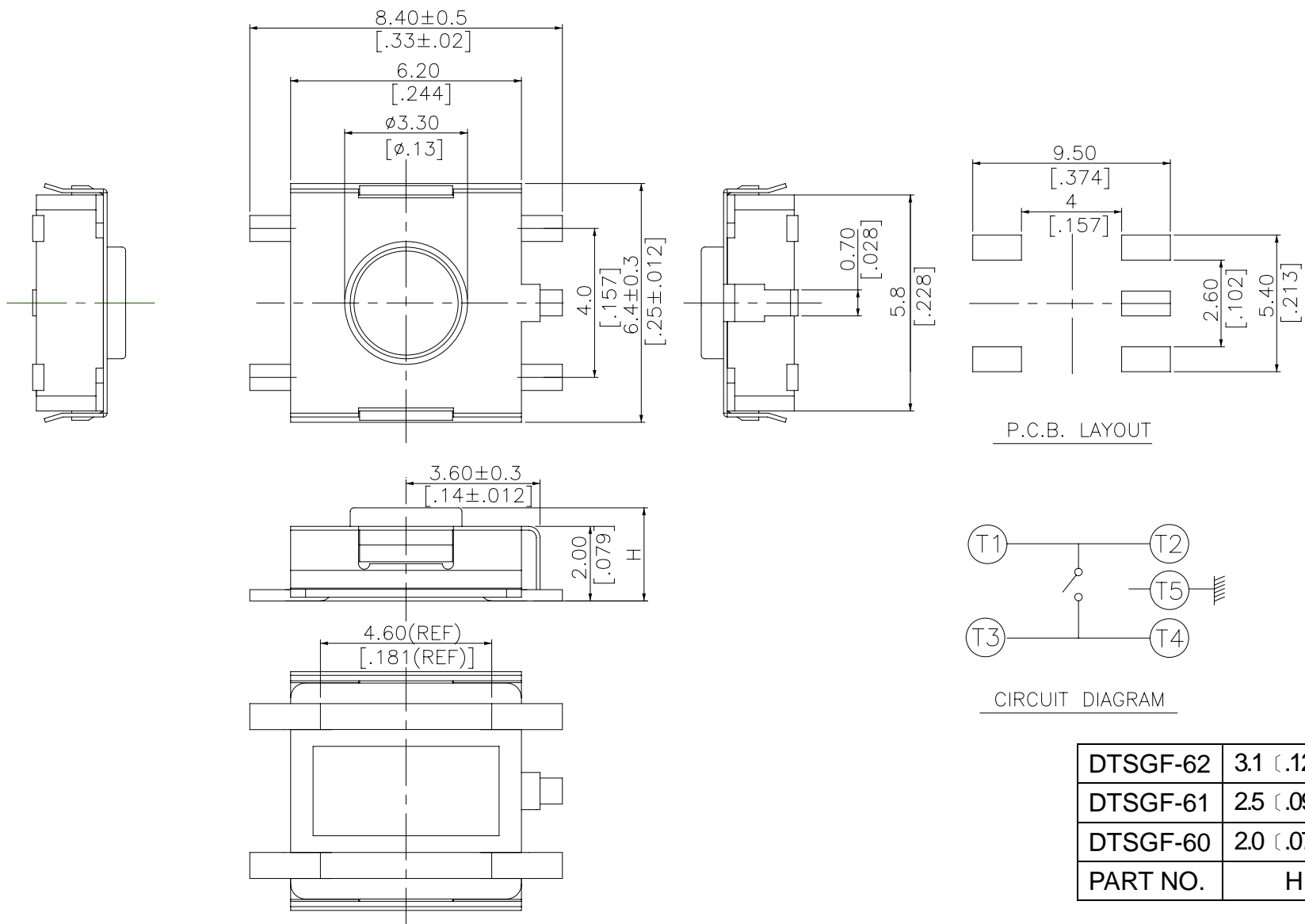

General Tolerance : ±0.2mm

DTSL-6

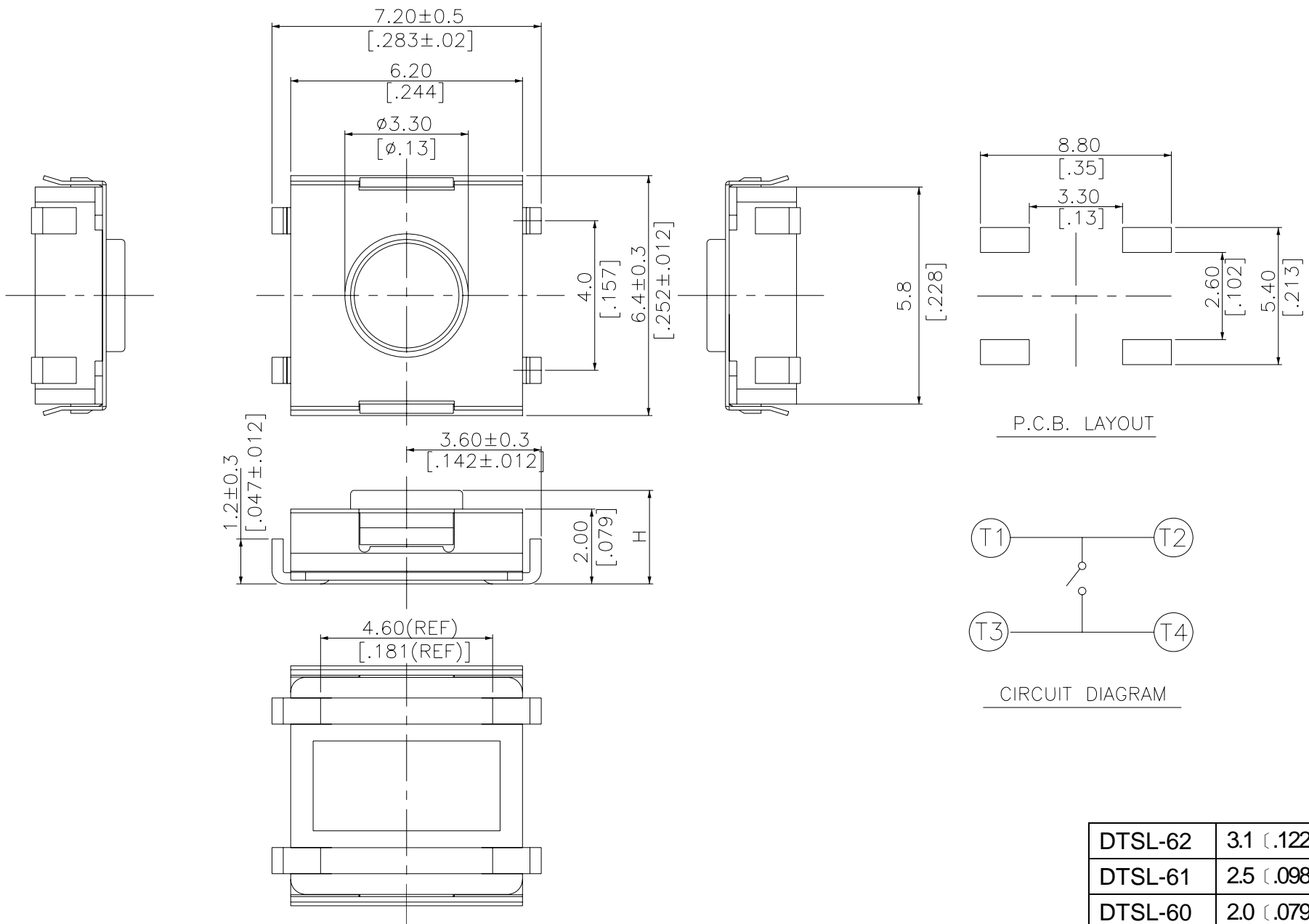

General Tolerance : ±0.2mm

DTSL-62	3.1 [.122]
DTSL-61	2.5 [.098]
DTSL-60	2.0 [.079]
PART NO.	H

DTSG-6

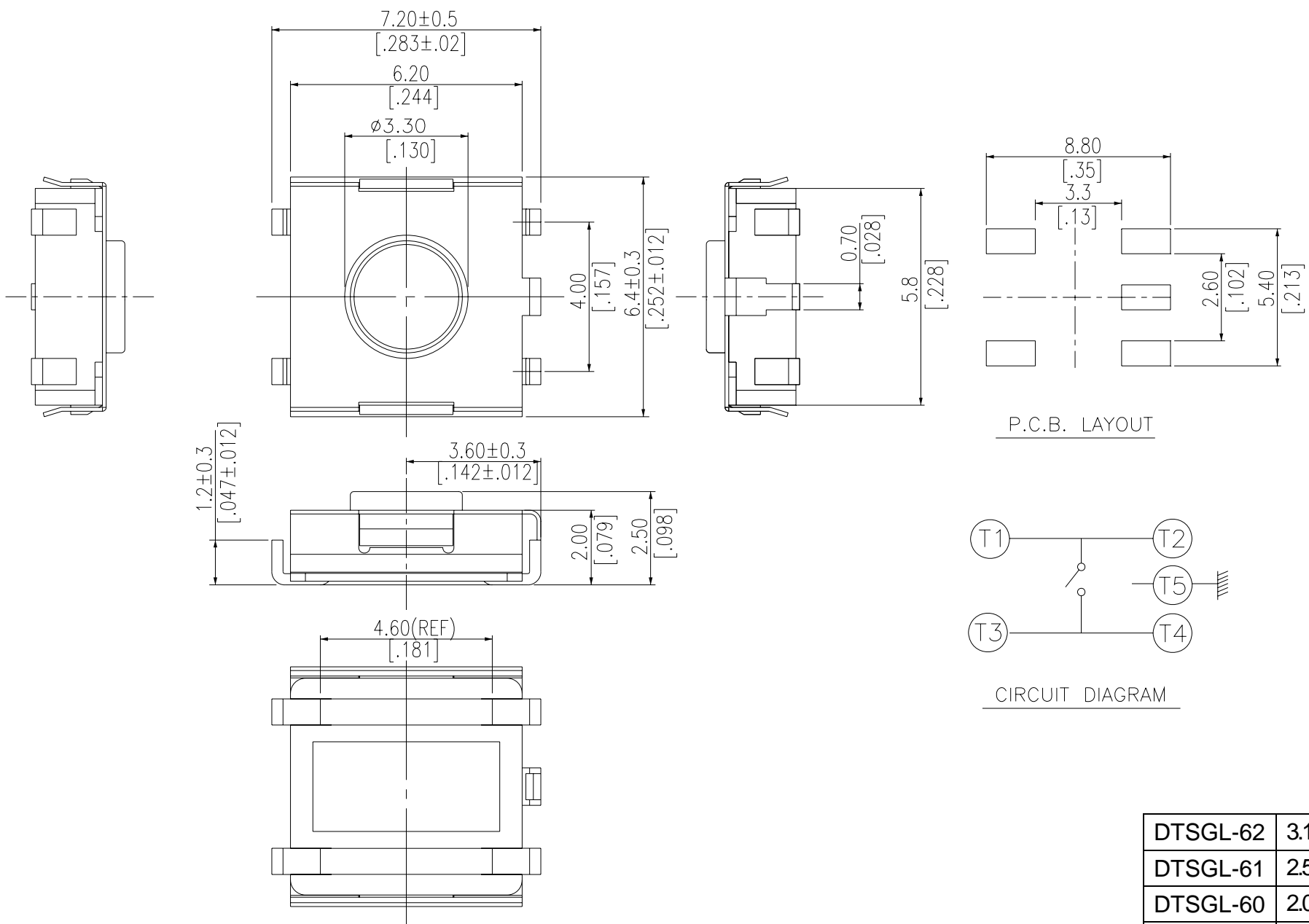

General Tolerance : ±0.2mm

DTSG-62	3.1 [.122]
DTSG-61	2.5 [.098]
DTSG-60	2.0 [.079]
PART NO.	H

HOW TO ORDER

DTS □ □ - 6 □ □ □ - □ - □

Package Style :

B = Tube

T/R = Tape & Reel

Soldering :

V = Lead Free Solderable

Q=Halogen Free

Stem Actuator :

□ = Soft <Only H : 3.1mm>

P = Hard <Actuator 3.1mm>

Color Of Stem For Operating Force :

K = Black, 100g

N = Brown, 160g

R = Red, 260g

S = White, 320g

Y = Yellow, 52g

N = Brown, 200g <Only Soft actuator>

Total Height :

0 = 2.0mm

1 = 2.5mm

2 = 3.1mm

Terminal Type :

L = J Bend

F = Flat

Prod. Series :

G = With Ground Terminal

□ = Without Ground Terminal

SPECIFICATION

△MECHANICAL

Operation Force: 100±50gf Black(K)
 160±50gf Brown(N)
 260±50gf Red(R)
 320±80gf White(S)
 520±130gf Yellow(Y)

Stroke: 0.25+0.2/-0.1mm

Operation Temperature: -25°C to +70°C

Storage Temperature: -30°C to +80°C

△ELECTRICAL

Electrical Life: 300,000 cycles for 320gf, 520gf
 500,000 cycles for 260gf
 1,000,000 cycles for 100gf, 160gf, 180gf

Rating : 50 mA , 12 VDC

Contact Resistance : 100mΩ max

Insulation Resistance : 100MΩ min , at 500 VDC

Dielectric Strength : 250 VAC / 1minute

Contact Arrangement : 1 pole 1 throw

MATERIAL

△COVER: Stainless steel (DTSL.F-6)
 Nickel Silver (DTSGL.F-6)

△BASE: UL 94V-0 Nylon High-temp thermoplastic
 Color: Black

△CONTACT DISC: Stainless steel

△TERMINAL: Brass with silver plated

△STEM : UL94V-0 Nylon High-temp Thermoplastic
 Color : Black(100gf) , Brown(160gf) , Red(260gf) ,
 White(320gf) , Yellow(520gf)
 Silicon Rubber Color : Brown (200gf)

SOLDERING CONDITIONS

△HAND SOLDERING : Use a soldering iron of 30 watts, Temperature Profile :
 controlled at 350°C approximately max 5 seconds while
 applying solder.

△REFLOW SOLDERING : When applying reflow
 Soldering , the peak temperature or the reflow oven
 should be set to 260°C max. Condition for soldering.
 (Reflow & Non-washable type)

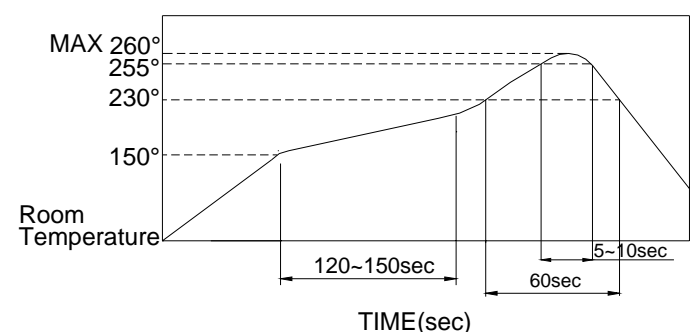

PACKING

Part Number	Number Per Tube	Number Per Reel
DTS(G)L-60(1)	75	2700
DTS(G)F-60(1)	75	3000
DTS(G)L-62	75	2500
DTS(G)F-62	75	2500

DTS(G)L、F-62 REEL

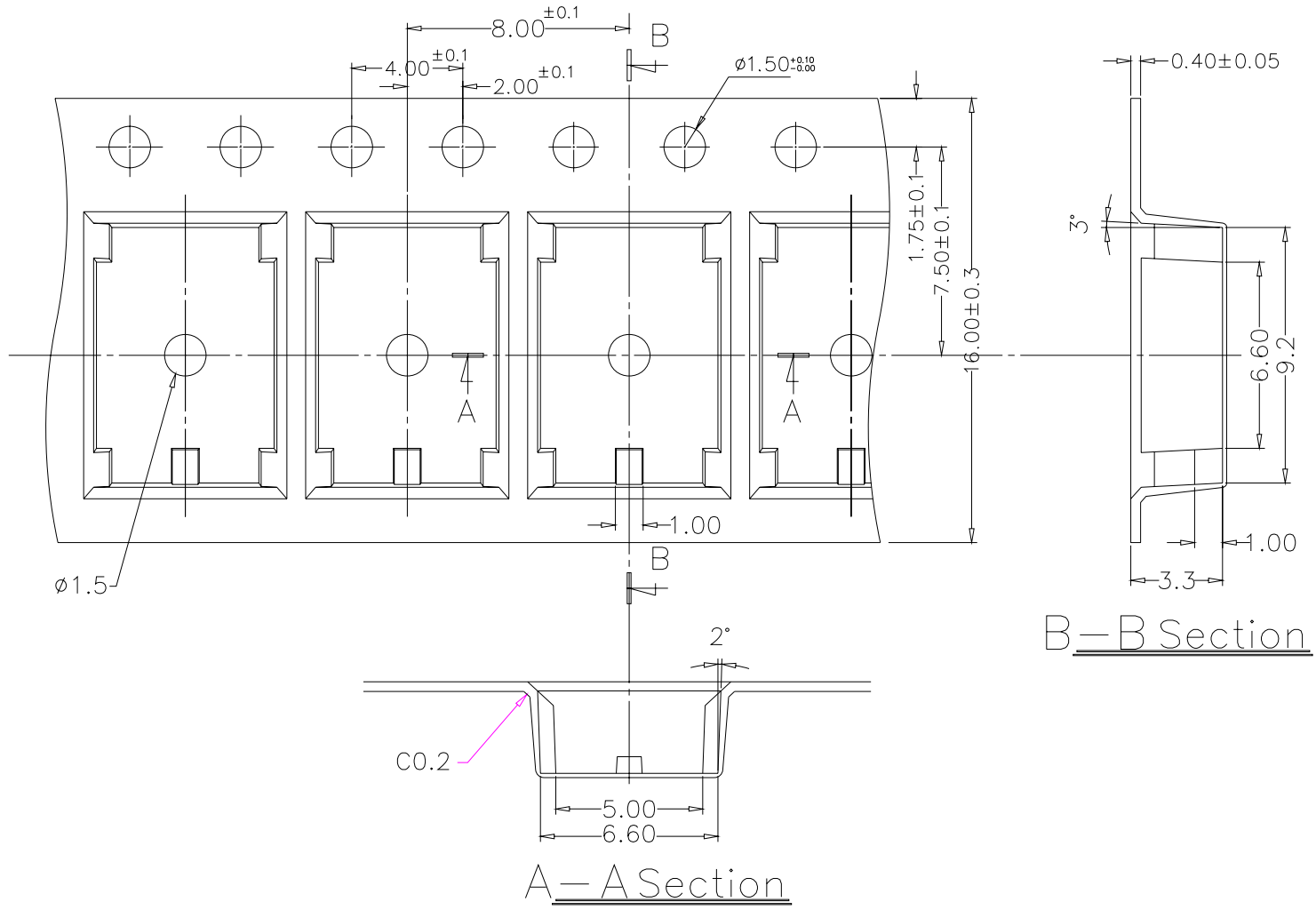

General Tolerance : ±0.1mm

DTS(G)L、F-60、61 REEL

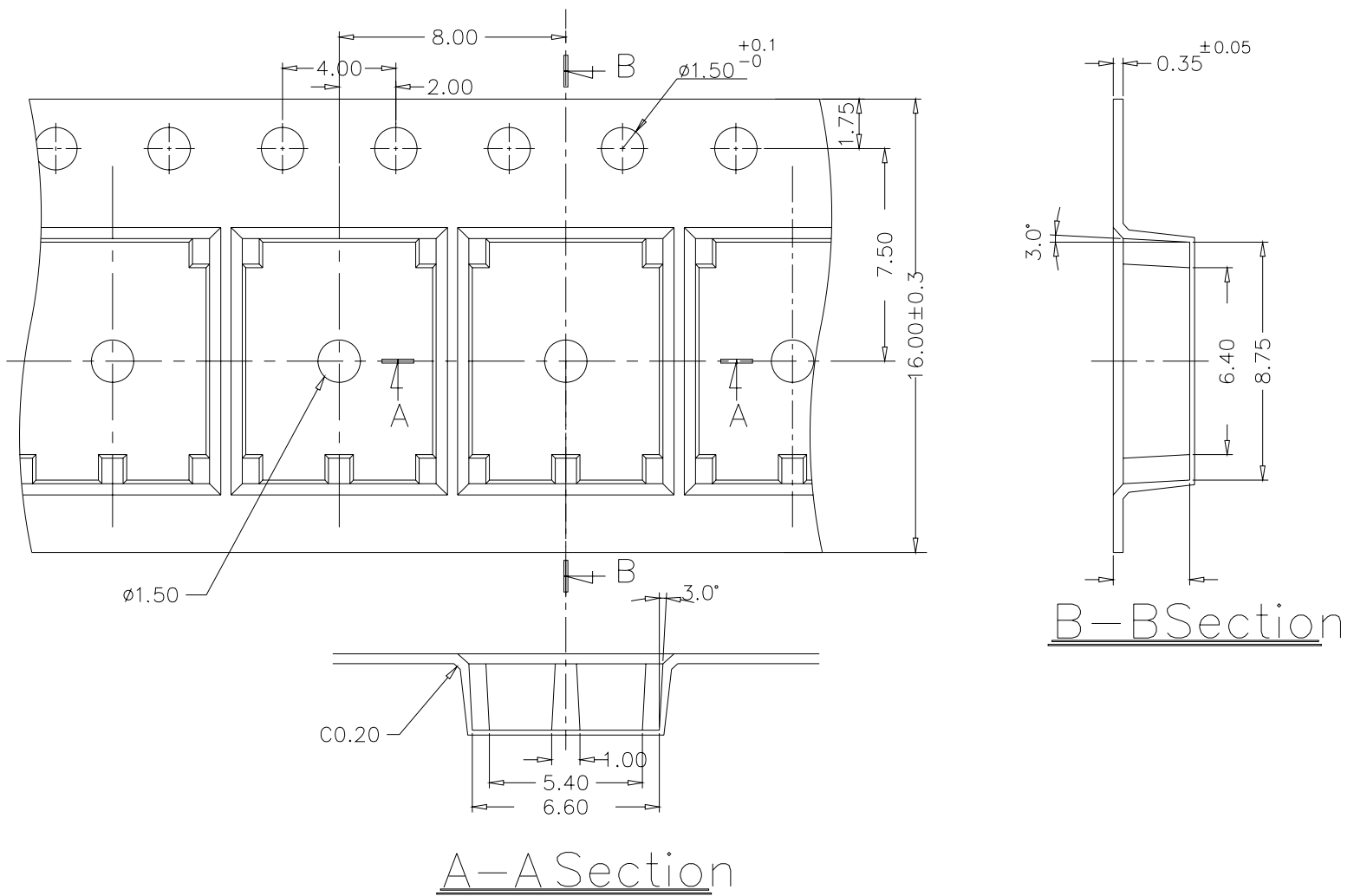

General Tolerance : ±0.1mm

DTS(G)L-6 TUBE

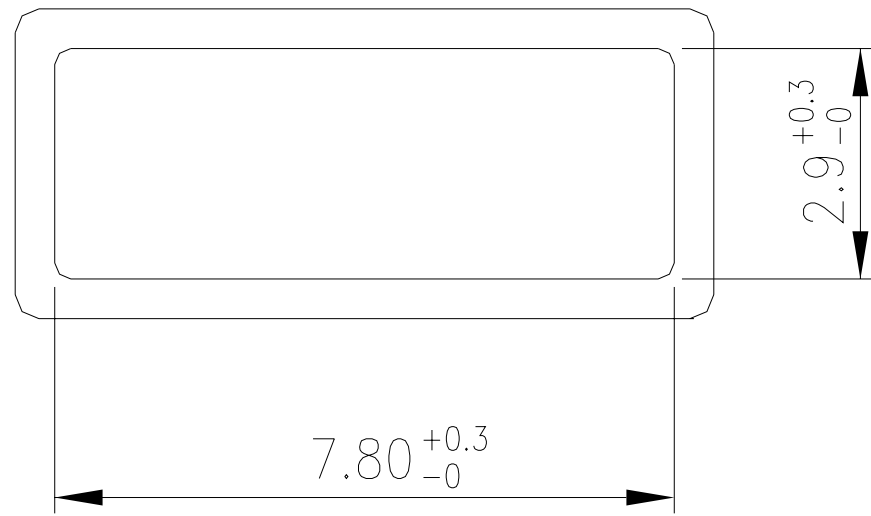

General Tolerance : ± 0.2 mm

DTSF-60、61 TUBE

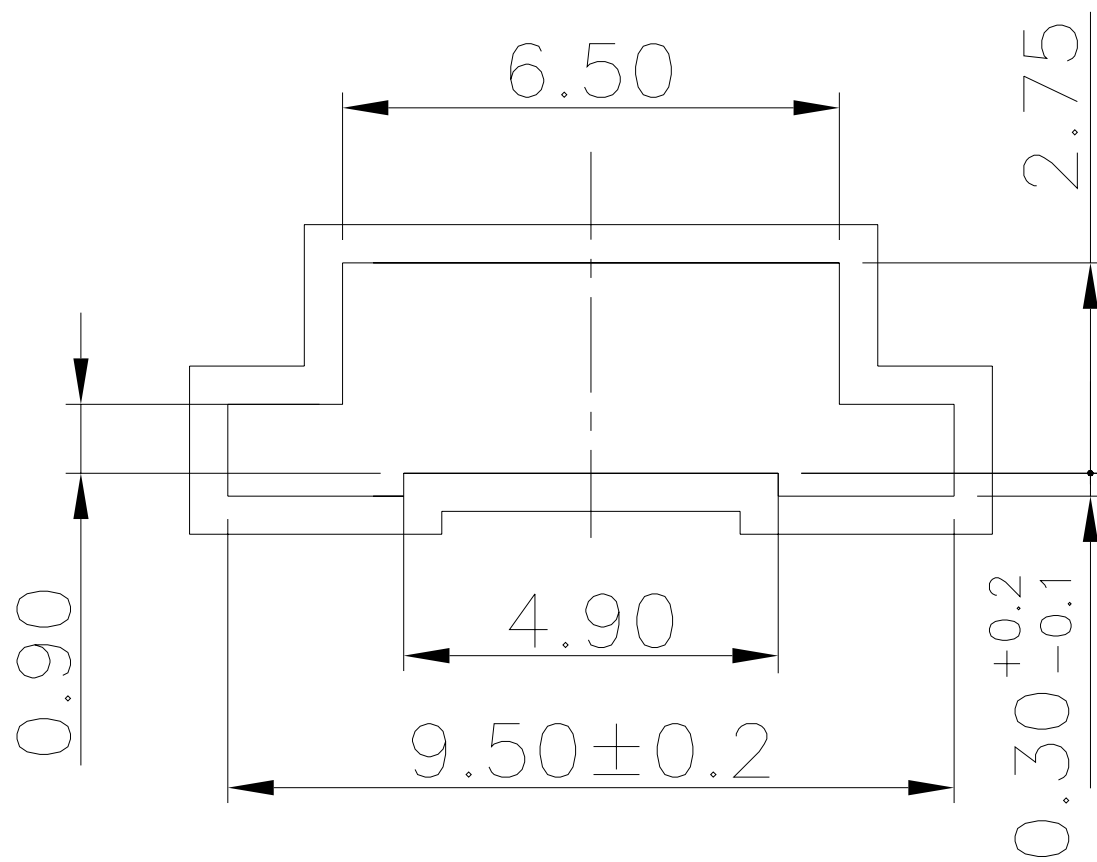

General Tolerance : ± 0.2 mm

DTSGF-60、61 TUBE

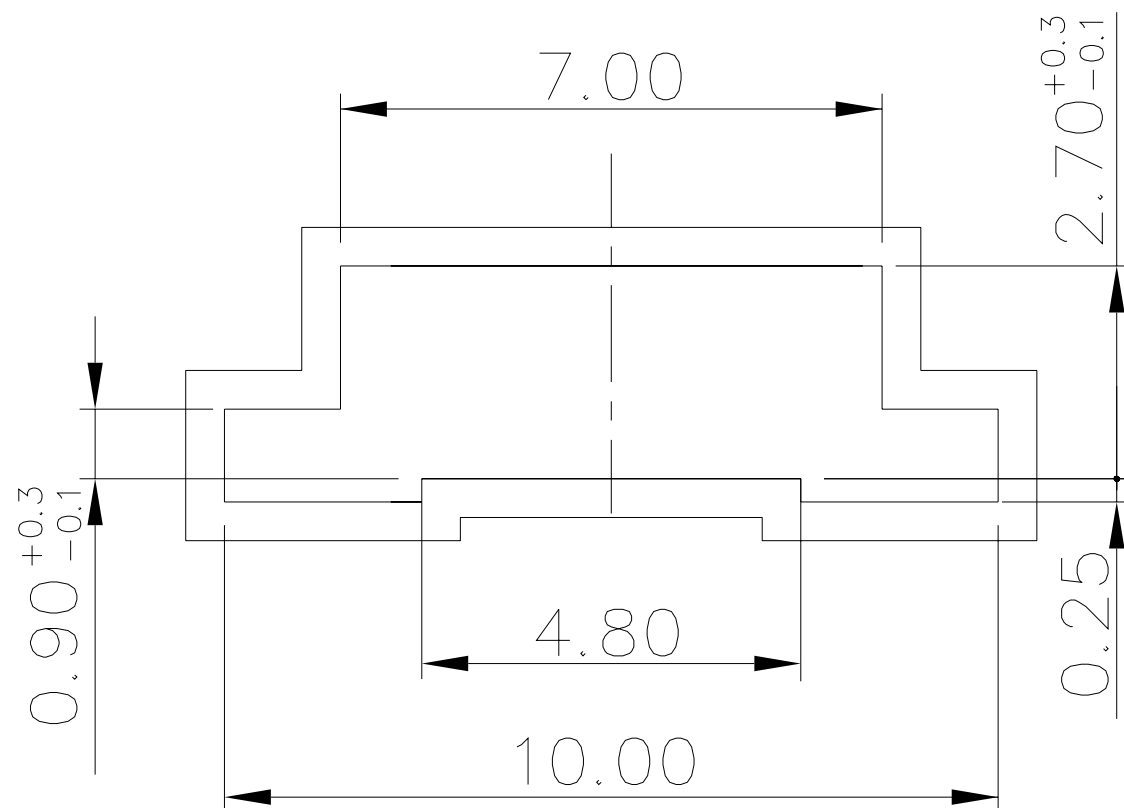

General Tolerance : $\pm 0.2\text{mm}$

DTS(G)F-62 TUBE

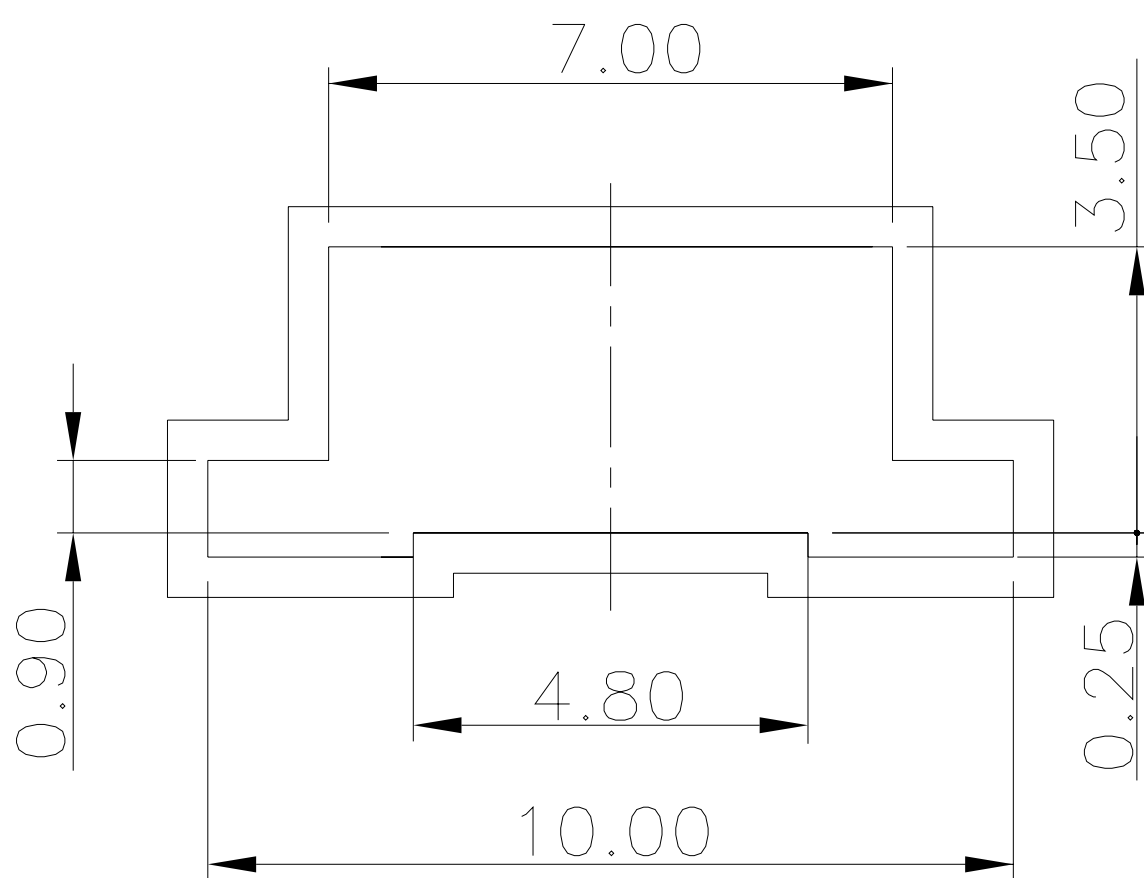

General Tolerance : $\pm 0.2\text{mm}$