

DIMENSIONS

LSS22

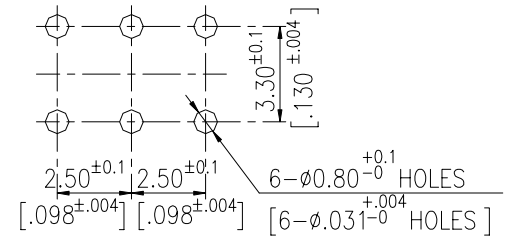
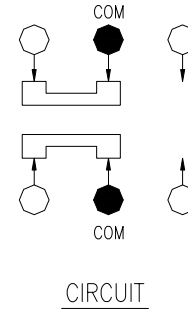
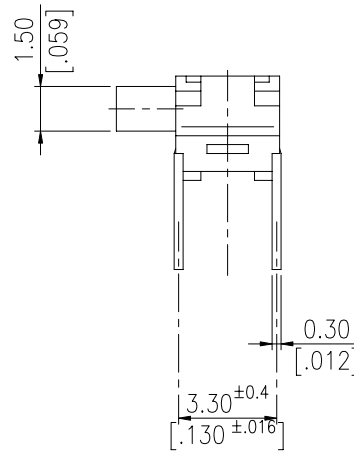
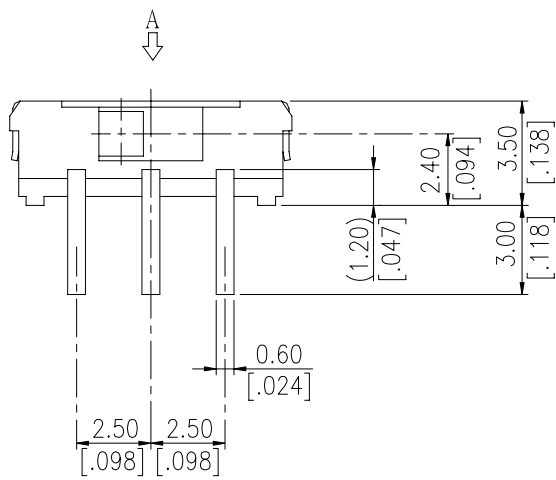
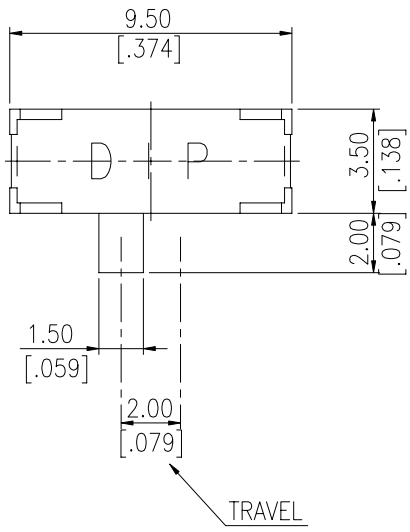

P.C.B. LAYOUT
(VIEW FROM THE DIRECTION A)

General Tolerance : $\pm 0.2\text{mm}$

LSS12

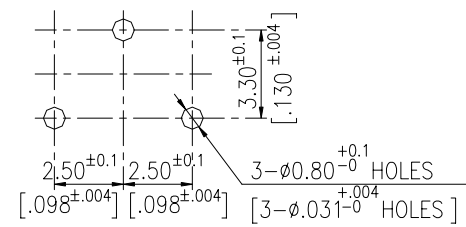
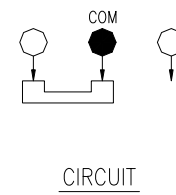
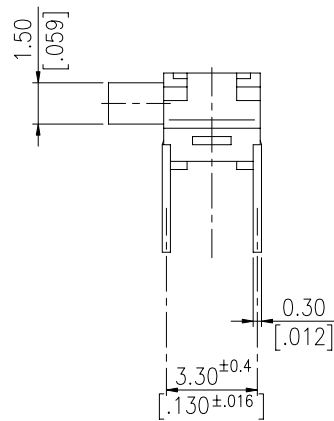
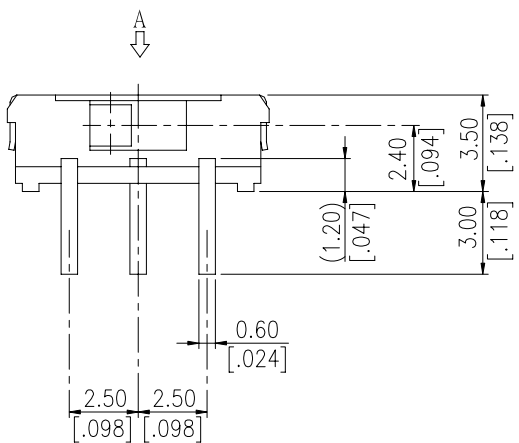
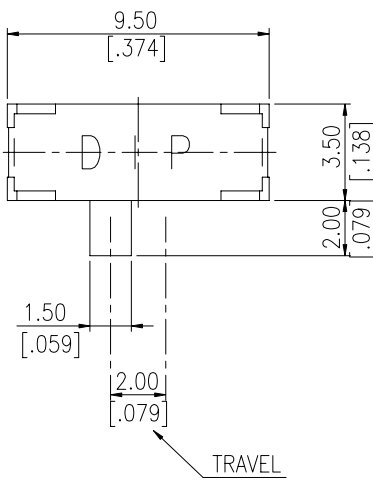

P.C.B. LAYOUT
(VIEW FROM THE DIRECTION A)

General Tolerance : $\pm 0.2\text{mm}$

LSSM12-P

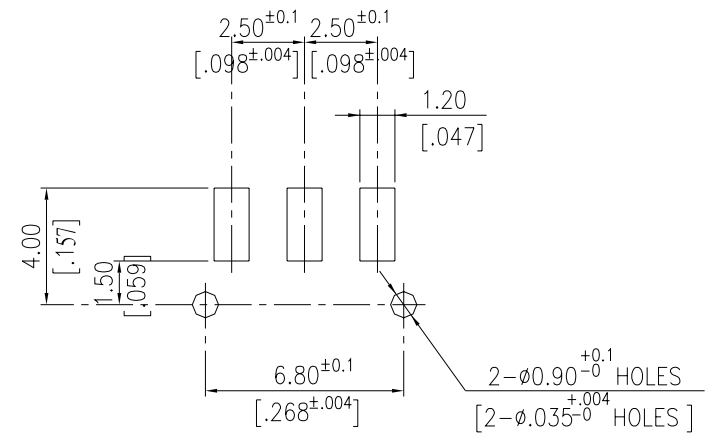
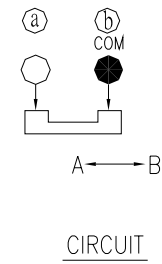
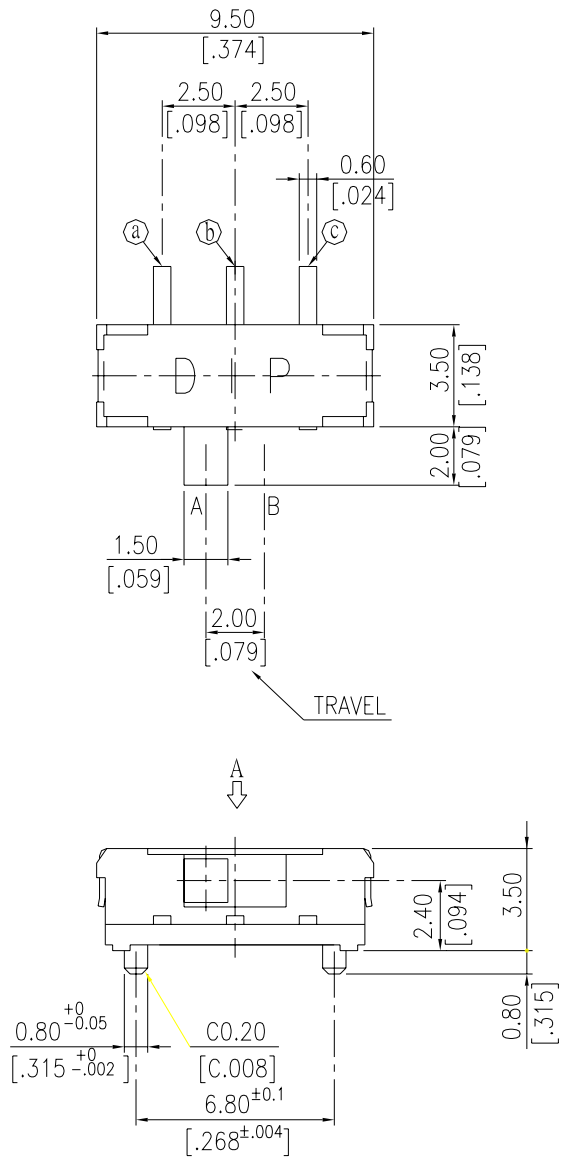

P.C.B. LAYOUT
(VIEW FROM THE DIRECTION A)

General Tolerance : $\pm 0.2\text{mm}$

HOW TO ORDER

L S S - - A - -

Package Style :

- = Bag
- B = Tube(Only for Lss)
- T/R = Tape & Reel

Soldering :

- V = Lead Free
- Q=Halogen Free

Stem direction:

- =LSS Stem in the Right
- LSS(A)M Stem in the Lift
- C =LSS Stem in the Lift
- LSS(A)M Stem in the Right

Frame style(Only for Through Hole)
H=5.0 mm

- =Without Pilot(Without S.M.T Type)
- P= Base With Pilot

STEM Length(Without LSSAM Type)
40=4.0mm(Only for Through Hole)
32=3.2mm(Only for Through Hole)

Terminal Length :

- = 3.0mm ; L = 2.50mm
- M= 2.20mm ; N= 1.80mm
- R= 1.20mm ; P= 1.0mm
- S= 0.9mm ; Q= 1.5mm

Number Of Pin :

- 12 = 1P2T
- 22 = 2P2T

Slide Direction :

- =Horizontal Slide
- M=Horizontal SMT Slide(Only for 1P2T)
- AM=Vertical SMT Slide

Slide Switch

SPECIFICATION

△MECHANICAL

Operation Force: 200±150

Stroke: 2mm

Operation Temp: -10°C to +60°C

Storage Temp: -20°C to +70°C

Rating : 0.1 A, 12 VDC

△ELECTRICAL

Electrical Life: 10,000 cycles

Non-switching Rating: 100mA, 50VDC

Switching Rating: 25mA, 24 VDC

Contact Resistance: 100mΩ max.

Insulation Resistance: 100MΩ min. (500VDC)

Dielectric Strength: 500VAC/ 1minute

Circuit: 1P2T, 2P2T

MATERIAL

△COVER: Stainless steel

△BASE: UL 94V-0 High-Temp thermoplastic

Color: Black

△ACTUATOR: UL 94V-0 High-Temp thermoplastic

Color: Black

△CONTACT: Alloy copper

△TERMINAL: Brass

SOLDERING PROCESS

△HAND SOLDERING : Use a soldering iron of 30 watts, Controlled at 350°C approximately 5 seconds while applying solder.

△REFLOW SOLDERING : When applying reflow soldering, the peak temperature or the reflow oven should be set to 260°C max.

PACKING

Part Number	Number Per Reel	Number Per Tube
LSS12、22-N、P、S、Q、R	900	50
LSS12、22-□、M、L	800	50
LSS12、22-40	800	-
LSSM12	1000	-
LSSAM12、22	800	-

LSS TUBE

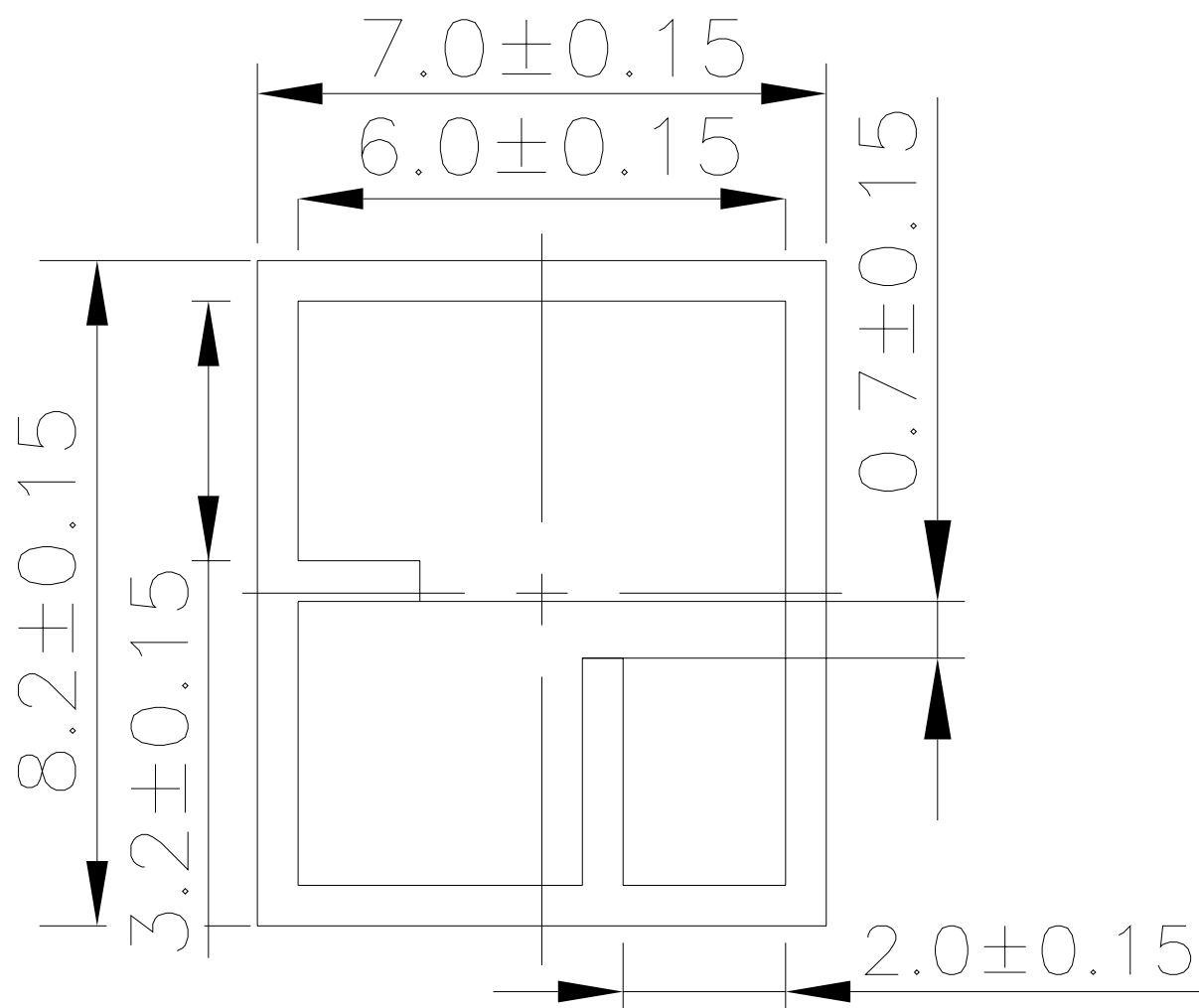

General Tolerance : ±0.2mm

LSS 12 · 22 REEL

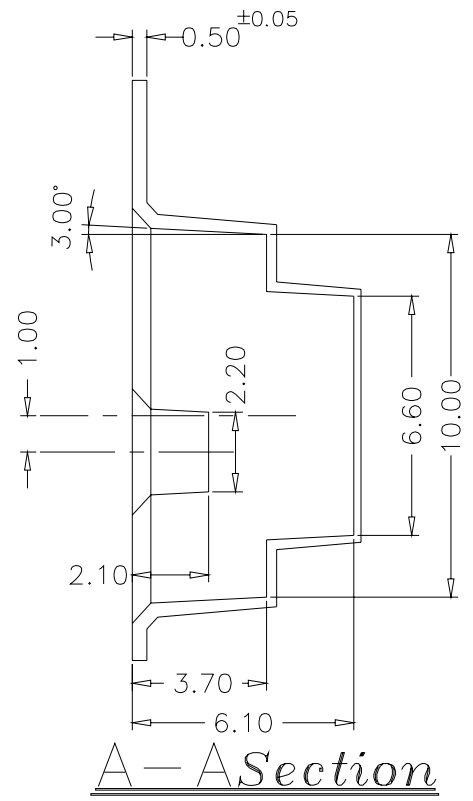
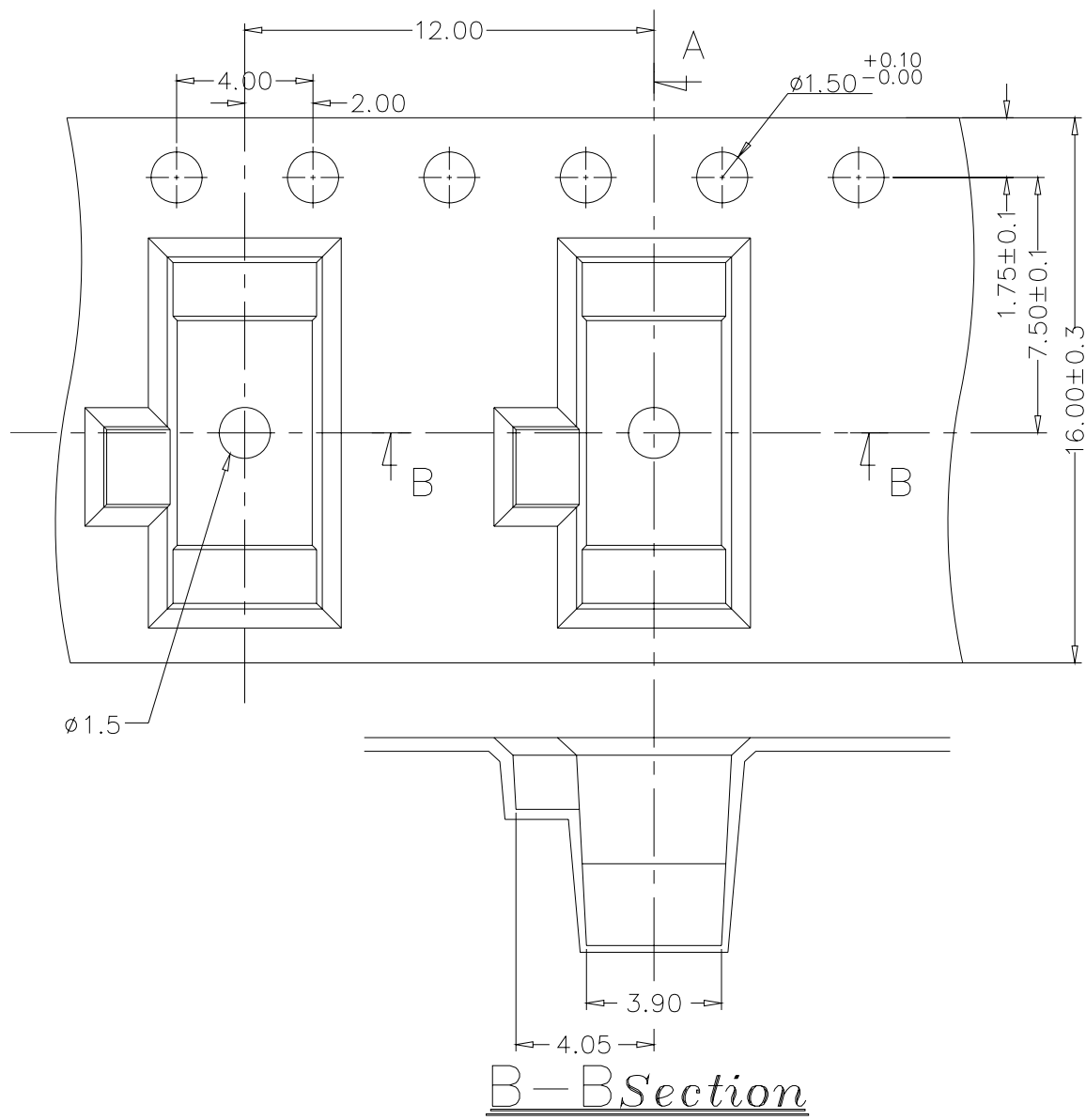

General Tolerance : ±0.1mm

LSS12 REEL

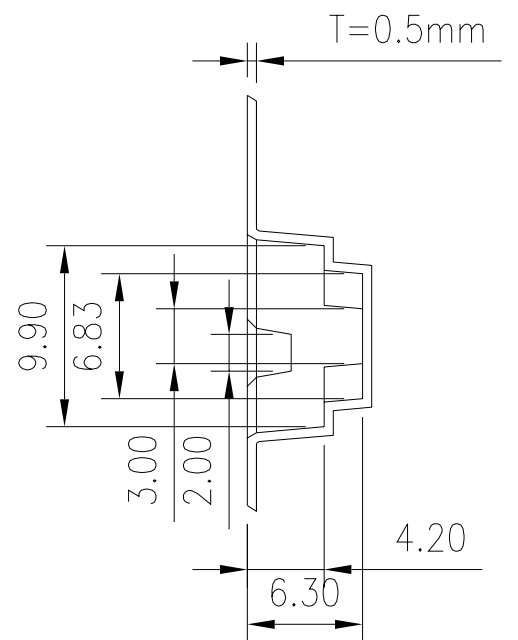
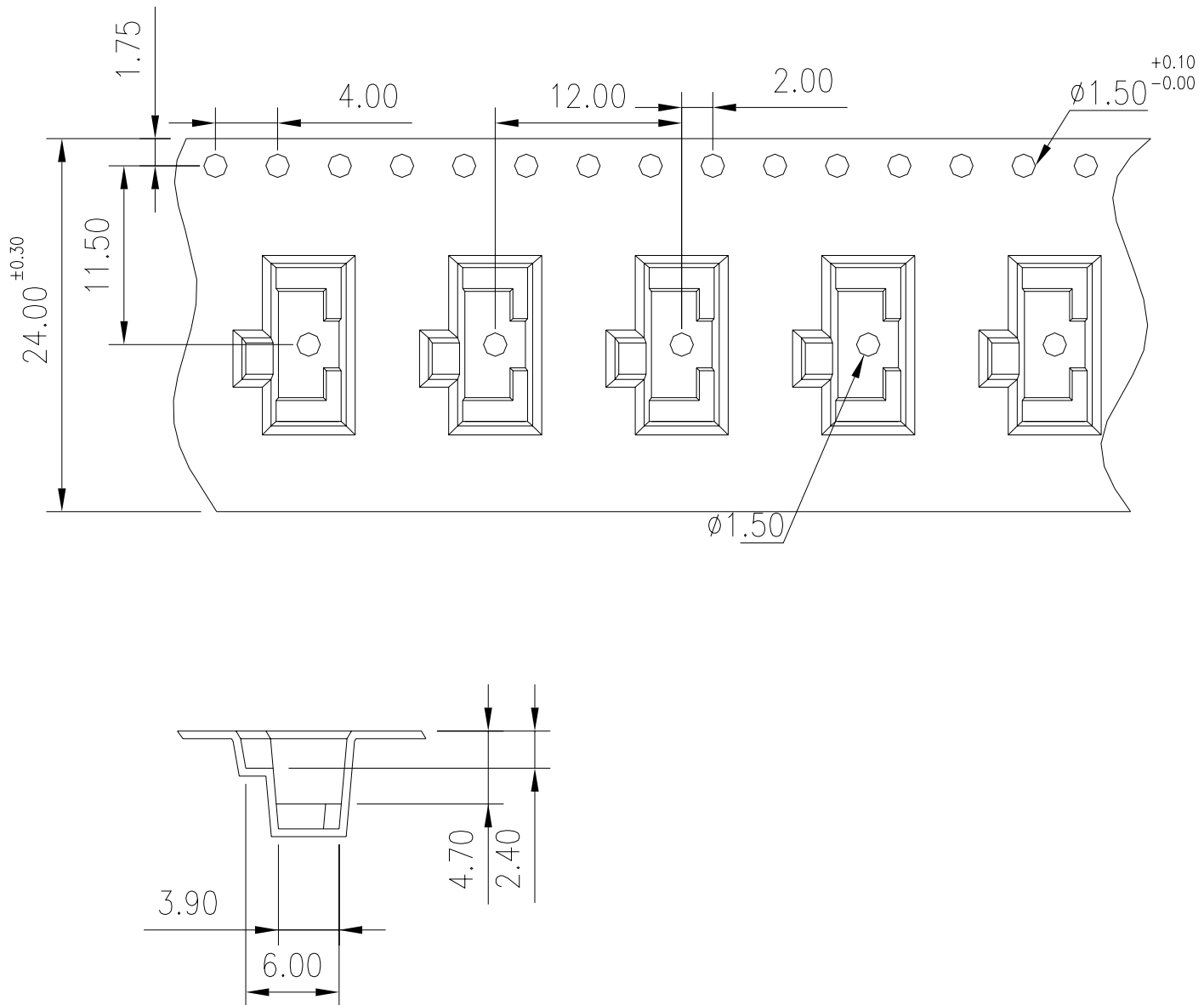

General Tolerance : ±0.1mm

LSSM REEL

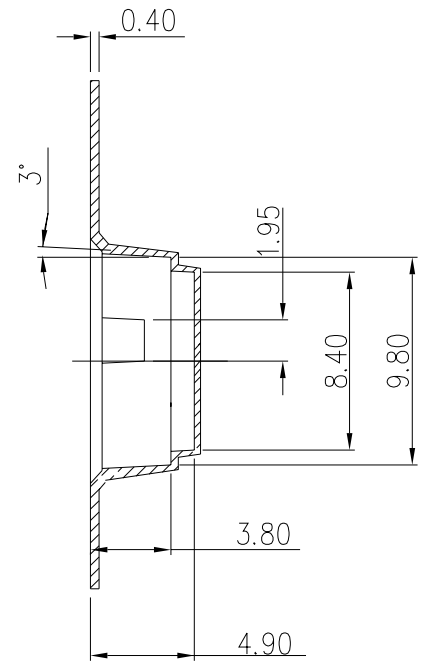
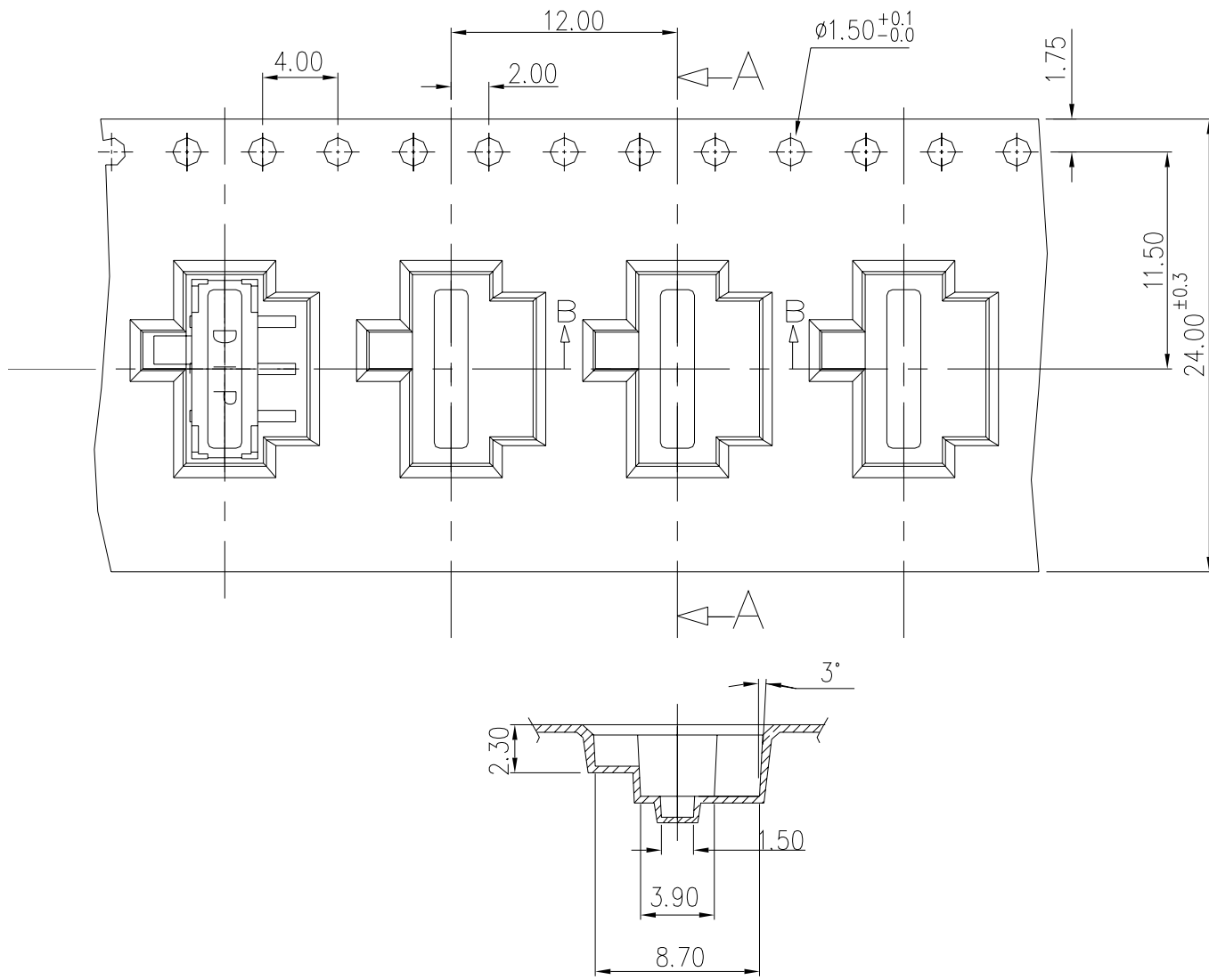

A-A Section

General Tolerance : ± 0.1 mm

LSSAM

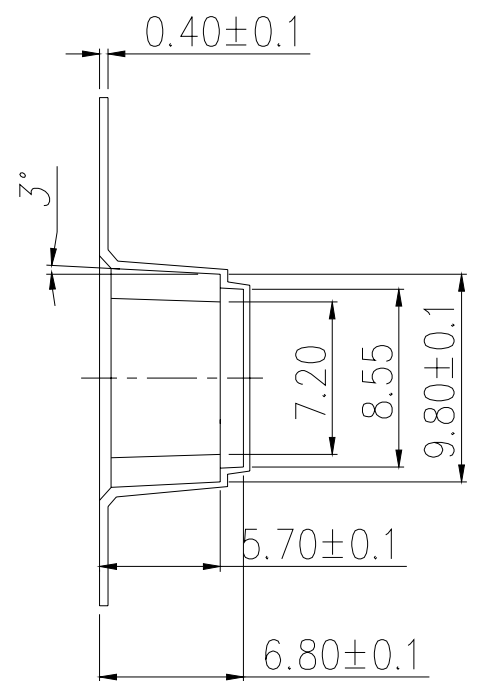
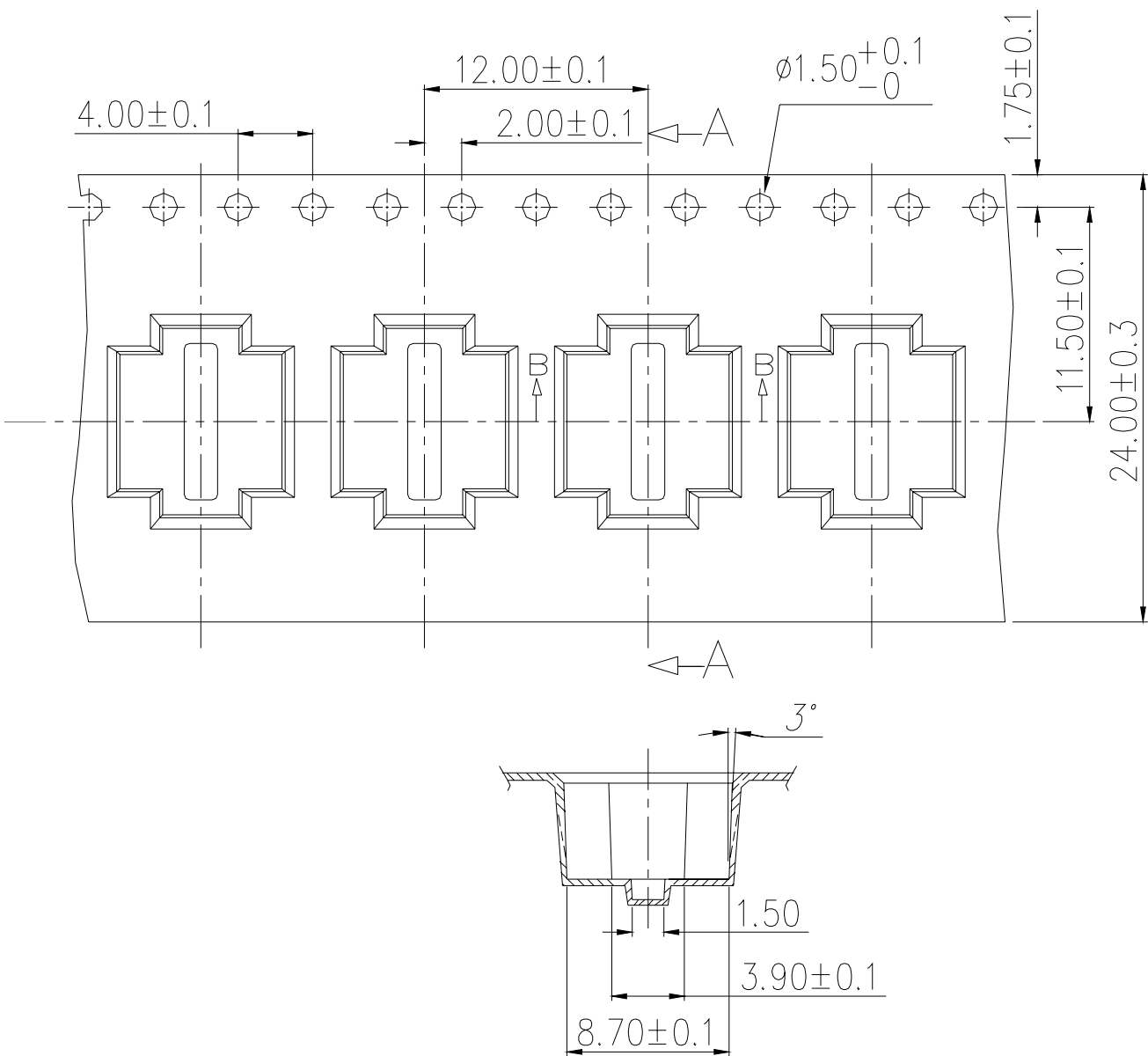

A-A Section

B-B Section