

LTL-6 SERIES

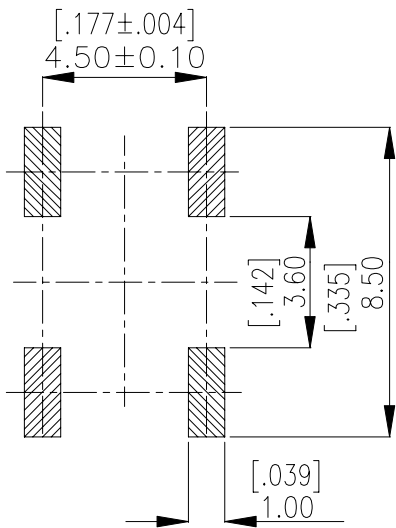

DIMENSIONS

LTL-6

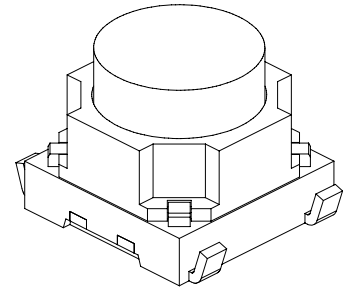
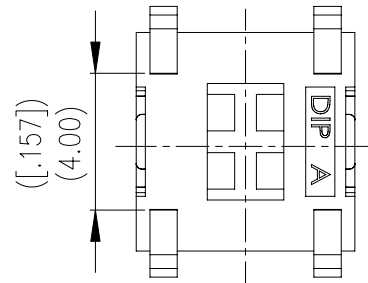
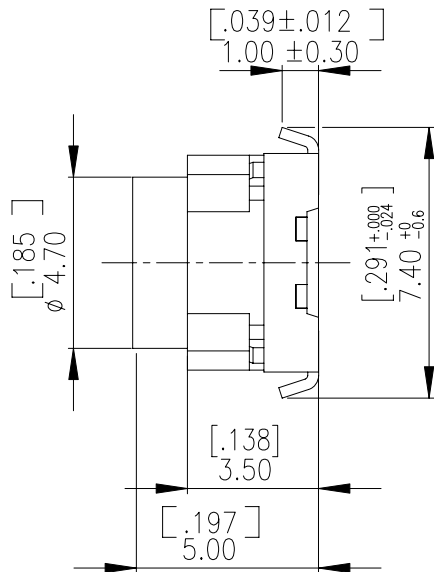
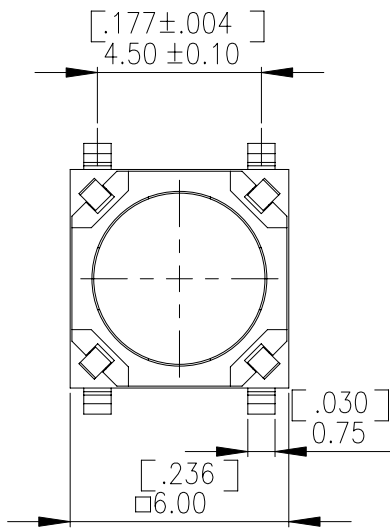

P.C.B. LAYOUT

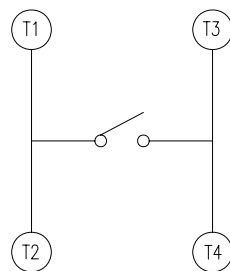

CIRCUIT DIAGRAM

NOTE:
1. ALL DIMENSIONS ARE IN MILLIMETER, BRACKETED DIMENSIONS ARE IN INCHES.
2. GENERAL TOLERANCES ±0.20mm.

HOW TO ORDER

LTL-6 13 □ V-T/R

Package Style :
T/R= Tape & Reel

Soldering :
V=Lead Free Solderable

Color of Stem for
Operating Force :
R= 200gf
S=350gf
Travel:
13= 1.3mm

Prod. Size:
6 X 6 mm

Terminal Type :
L= With L S.M.T terminal

Long travel Tact Switch

SPECIFICATION

△MECHANICAL

Operation Force: 200±50gf (R)
350±50gf (S)

Operation Temperature: -40°C to +85°C

Storage Temperature: -40°C to +85°C

Stroke: 1.30+0.10/-0.30mm

△ELECTRICAL

Electrical Life: 30,000 cycles for 350gf
100,000 cycles for 200gf

Rating: 50 mA 12 V DC.

Contact Resistance: 100mΩ max. at 500VDC

Insulation Resistance: 100MΩ min. at 500VDC

Dielectric Strength: 300V AC/1 minute.

Contact Arrangement: 1pole 1throw

MATERIAL

△COVER : NYLON UL 94V-0 High-Temp Thermoplastic

Color: Black.

△Silicone Dome : Silicone rubber with metal contact
With Gold Plating

△STEM : NYLON UL 94V-0 High-Temp Thermoplastic

Color: Red.

△BASE : NYLON UL 94V-0 High-Temp Thermoplastic

Color: Black.

△TERMINAL : Brass , With Silver Plating

SOLDERING PROCESSES

△HAND SOLDERING : Use a soldering iron of 30 watts, controlled at 350°C approximately max 5 seconds while applying.

△REFLOW SOLDERING: When applying reflow soldering, the peak temperature or the reflow Oven should be set at 260°C max.

△Reflow Temperature Profile:

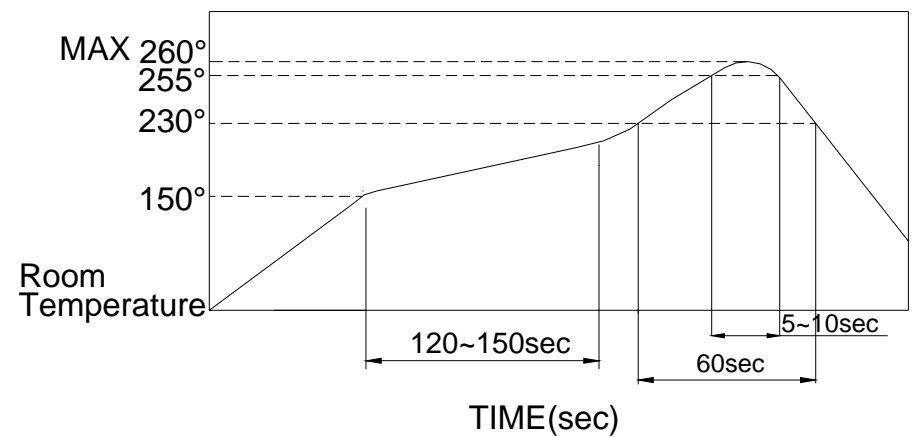

PACKING

Part Number	Number Per Tube	Number Per Reel
	-	900

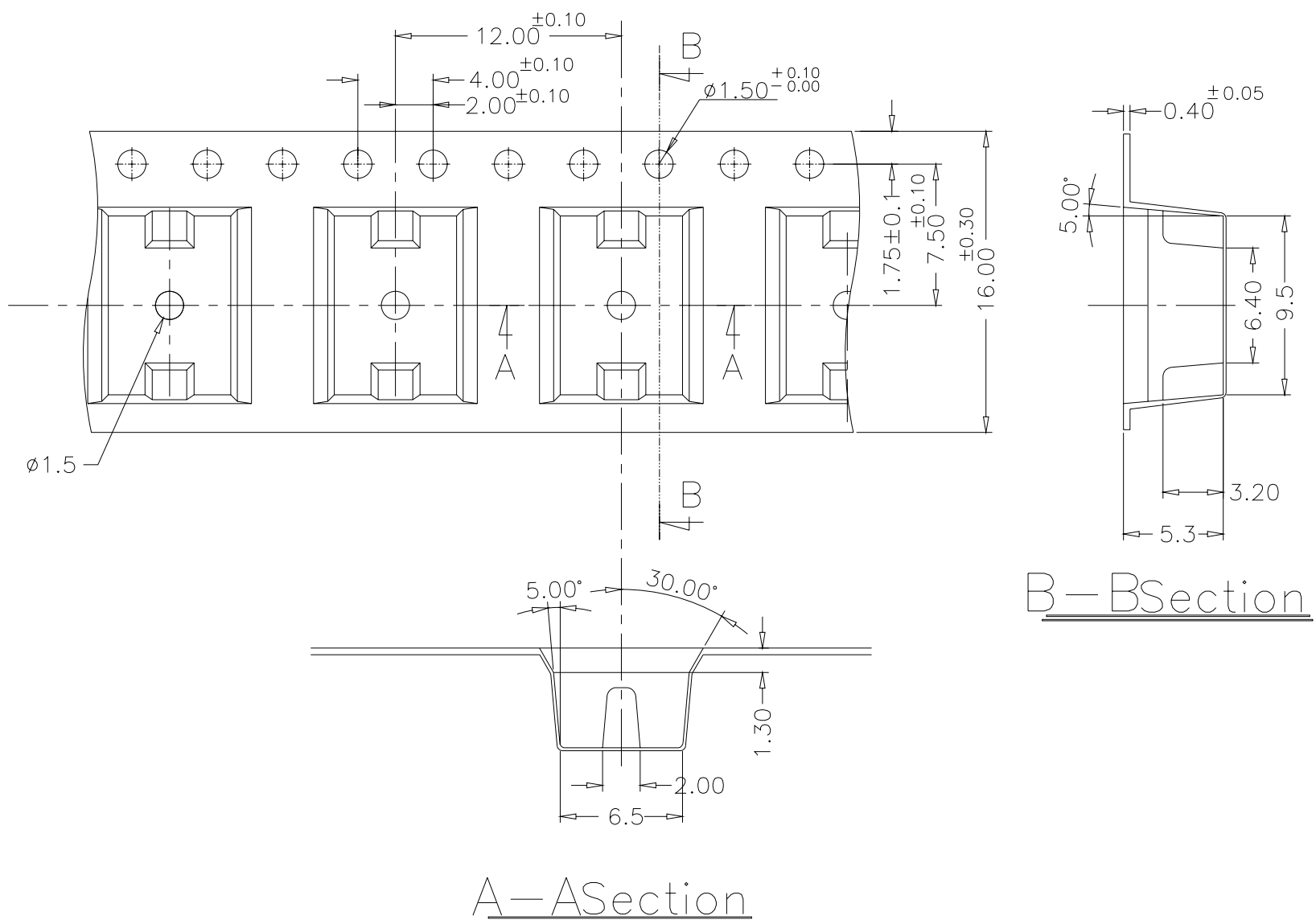

General Tolerance : ±0.1mm