



T□4 SERIES



DIMENSION

TA4

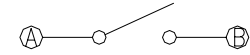
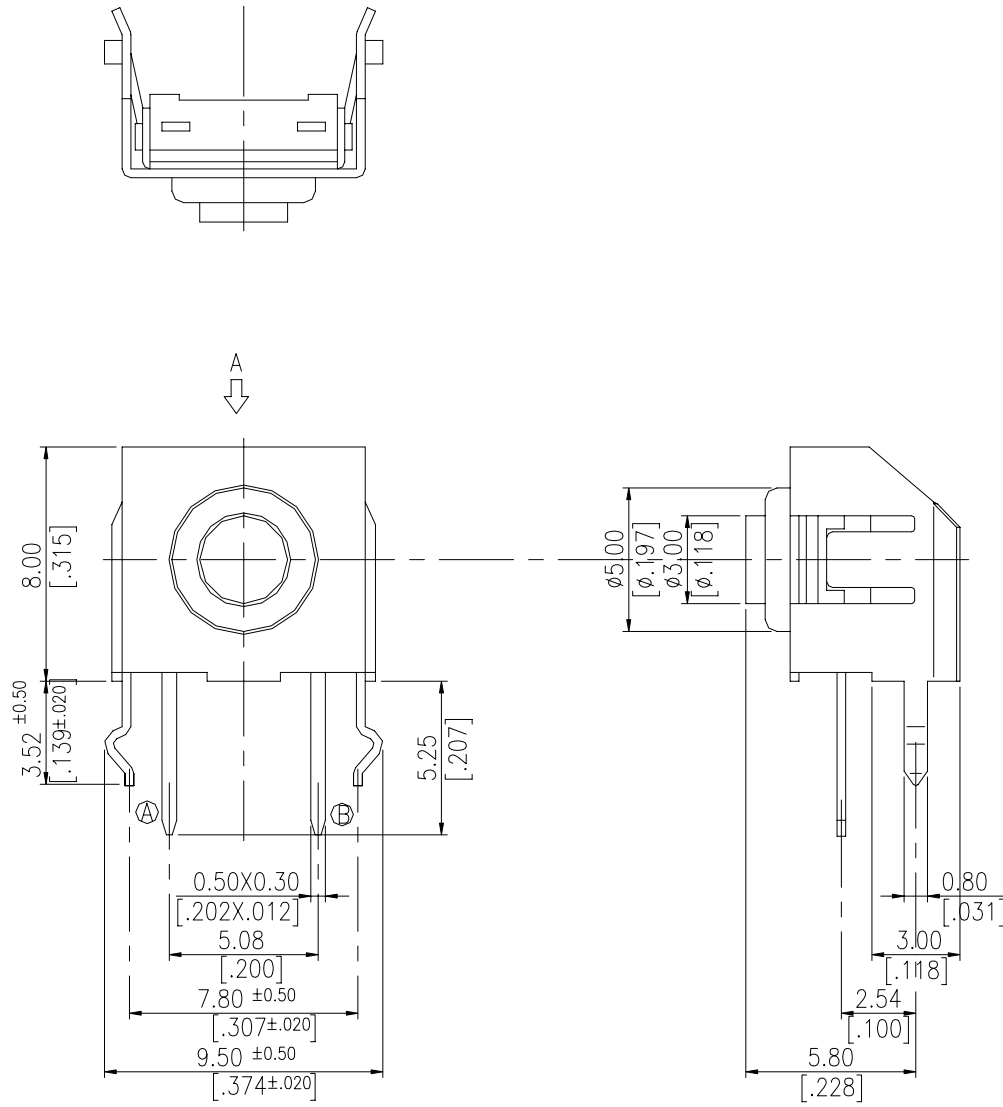

CIRCUIT

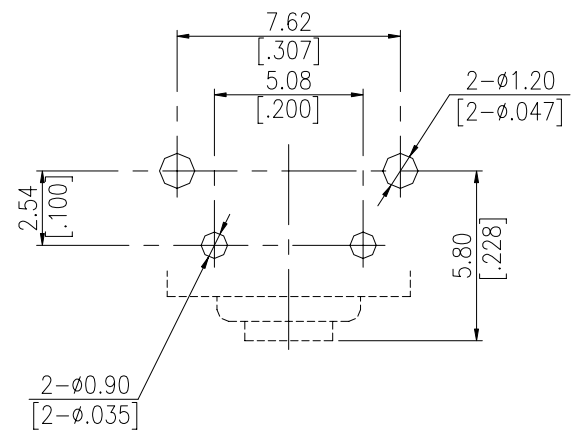

P.C.B. LAYOUT
(VIEW FROM THE DIRECTION A)

General Tolerance : ±0.2mm

TH4

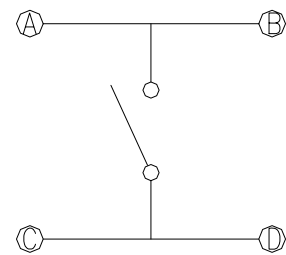
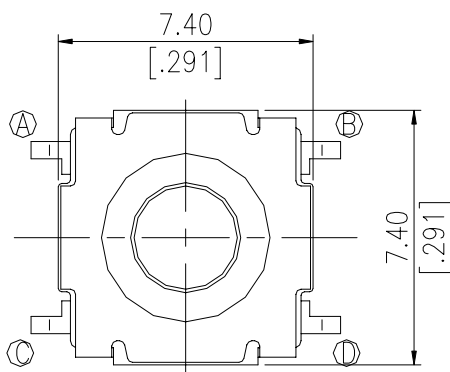

CIRCUIT

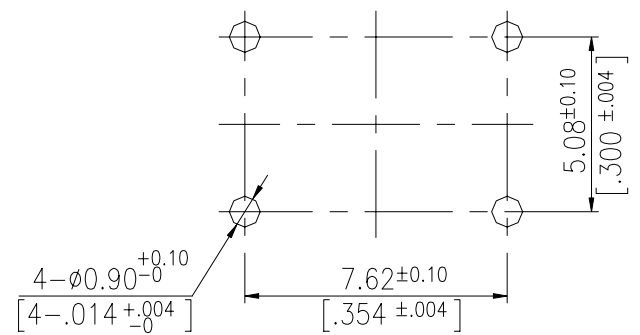
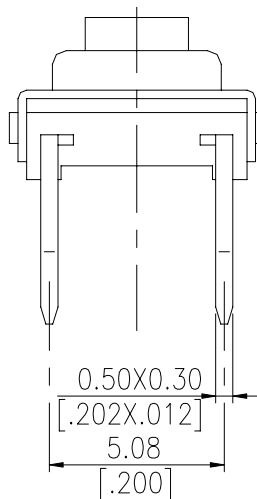
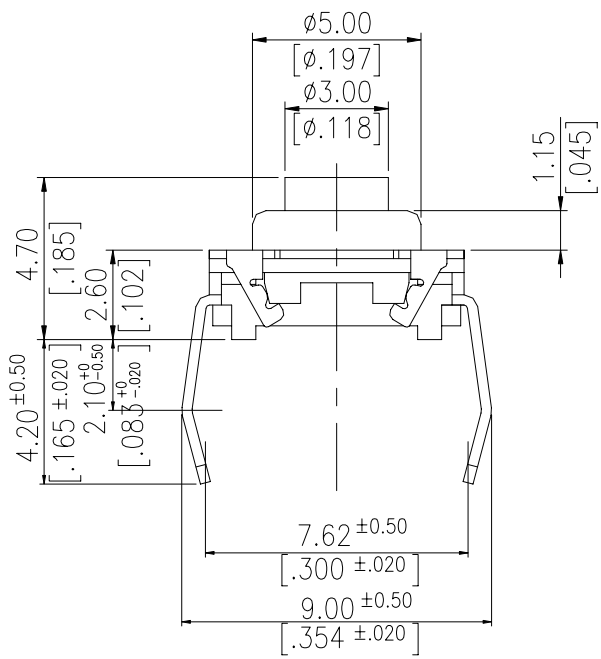

P.C.B. LAYOUT

General Tolerance : ±0.2mm

HOW TO ORDER

T □ 4 - □ □ □ □ □ - V - □

Package Style :

□ = Bulk

Soldering :

V = Lead Free Solderable

Plating :

□ = Plating Silver

Operating Force :

1 = 130gf

Color of Stem :

G = Green

S = Salmon

Stem Height :

58 = 5.8mm(Only Right angle series)

47 = 4.7mm(Only Through hole type)

Termination :

A = Right angle Series

H = Through hole

SPECIFICATION

△MECHANICAL

Mechanical Life : 1,000,000 cycles

Operation Force : 130±50gf 、 300±90gf

Stroke : 0.5±0.2mm

△ENVIRONMENTAL

Operation Temperature Range : -40°C to +90°C

Storage Temperature Range : -40°C to +90°C

△ELECTRICAL

Electrical Life: 1,000,000 cycles for 130gf

500,000 cycles for 300gf

Switching Rating: 50 mA, 50 VDC

MATERIAL

△BRACKET : Phosphor Bronze with silver plating

△COVER : Brass

△BASE : UL 940V-0 NYLON High-temp thermoplastic

Color : Black

△STEM : UL 940V-0 NYLON High-temp thermoplastic

Color : with silver plating

△TERMINAL : Brass with silver plating

△SILICONE RUBBER : Silicone

Color : White

△DOME : Stainless Steel

SOLDERING PROCESS

△HAND SOLDERING : Us a soldering iron of 30 watts, controlled at 350°C approximately 5 seconds while applying solder.

△WAVE SOLDERING : Recommended solder temperature

At 500° F(260°C)max. 5 seconds.

PACKING

Part Number	Number Per Reel	Number Per Bulk
T□4-58G1-V	-	500
T□4-58K1-V	-	500