



TAC-3 & TA(N)2-3 SERIES



DIMENSION

TAC-3

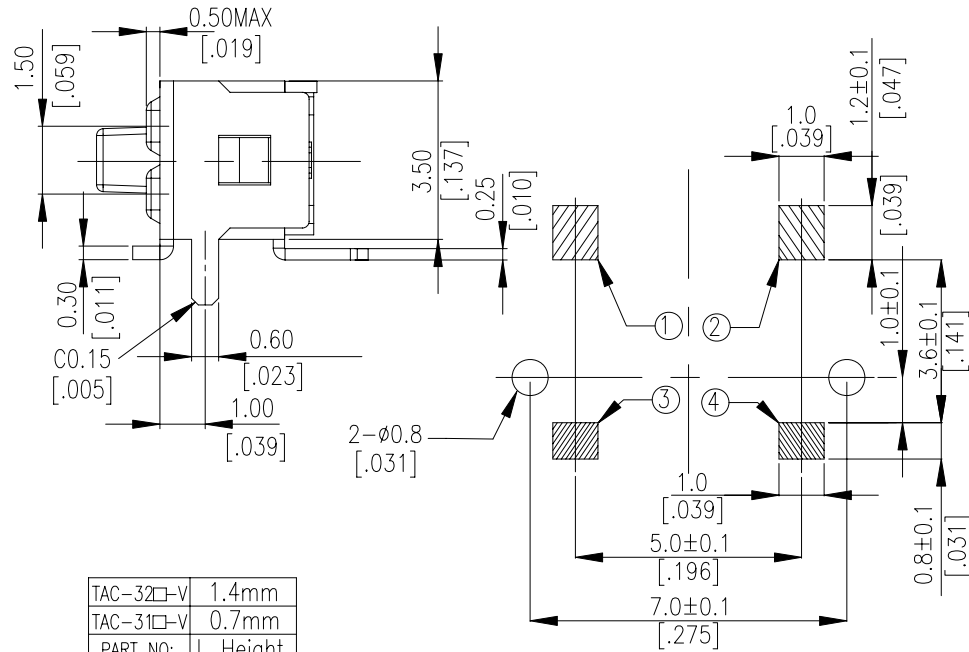
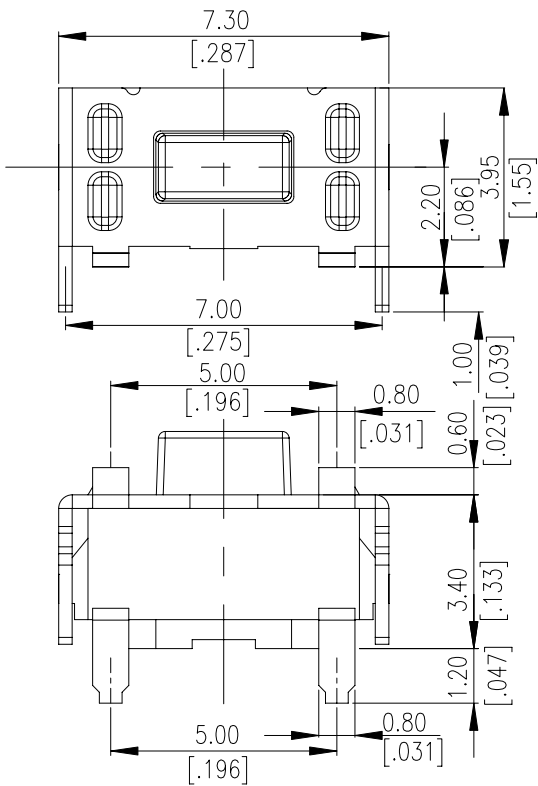
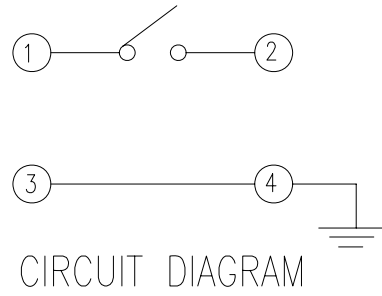
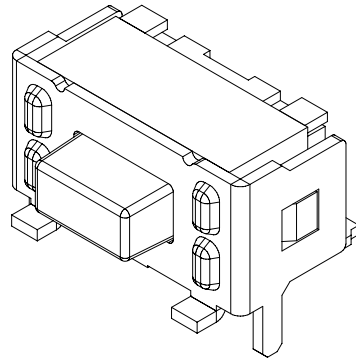
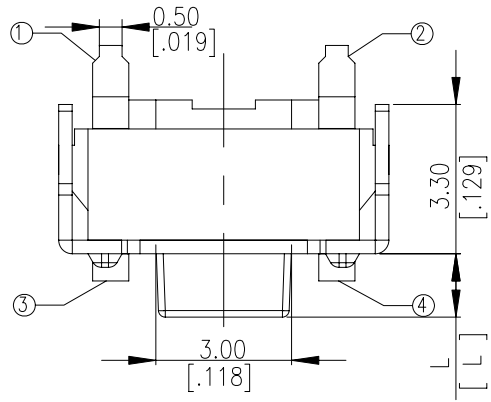

TAC-3□-V	1.4mm
TAC-3□-V	0.7mm
PART NO:	L Height

General Tolerance : ±0.2mm

TAN2-3

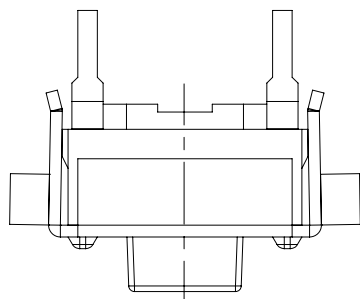

附表一

TAN2-32	1.4 [.055]	S SALMON 320g W WHITE 160g
TAN2-31	0.7 [.028]	S SALMON 320g W WHITE 160g
PART NAME:	L	COLOR FOR OPERATING FORCE

CIRCUIT DIAGRAM

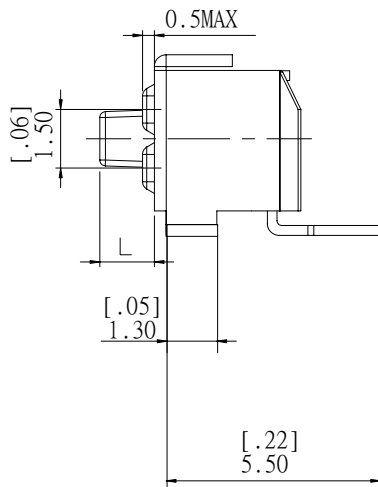
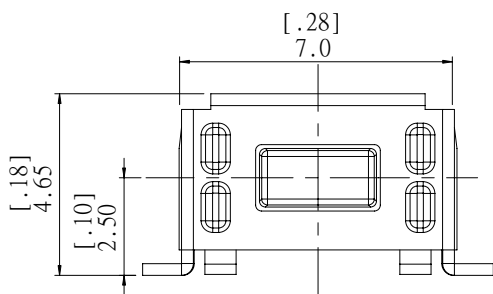
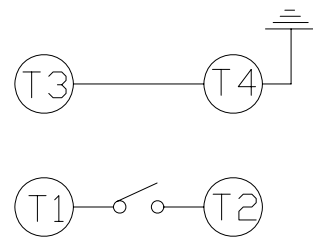

P.C.B. LAYOUT

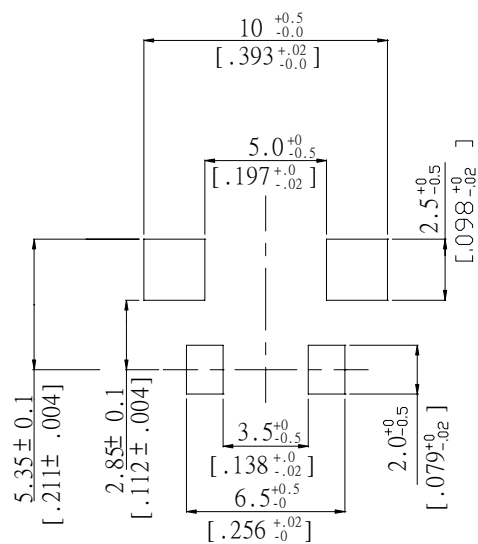
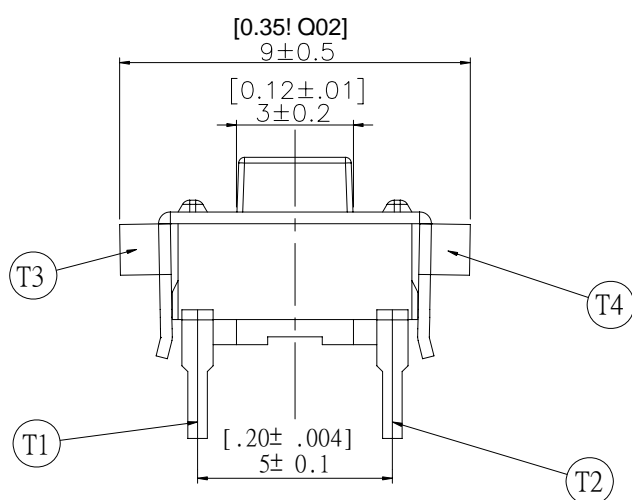

General Tolerance : ±0.2mm

TA2-3

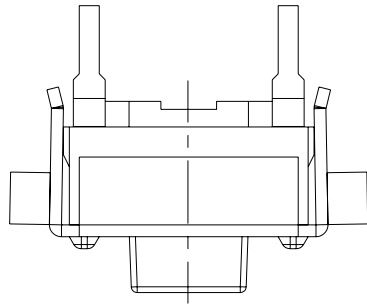

附表一

TA2-32□-V	1.4 [.055]	S	SALMON 320g
		W	WHITE 160g
		N	BROWN 160g
TA2-31□-V	0.7 [.028]	S	SALMON 320g
		W	WHITE 160g
		N	BROWN 160g
PART NAME:	L	COLOR FOR OPERATING FORCE	

CIRCUIT DIAGRAM

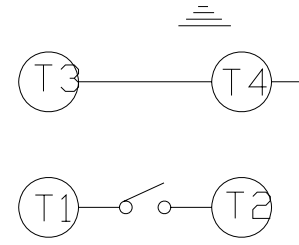

P.C.B. LAYOUT

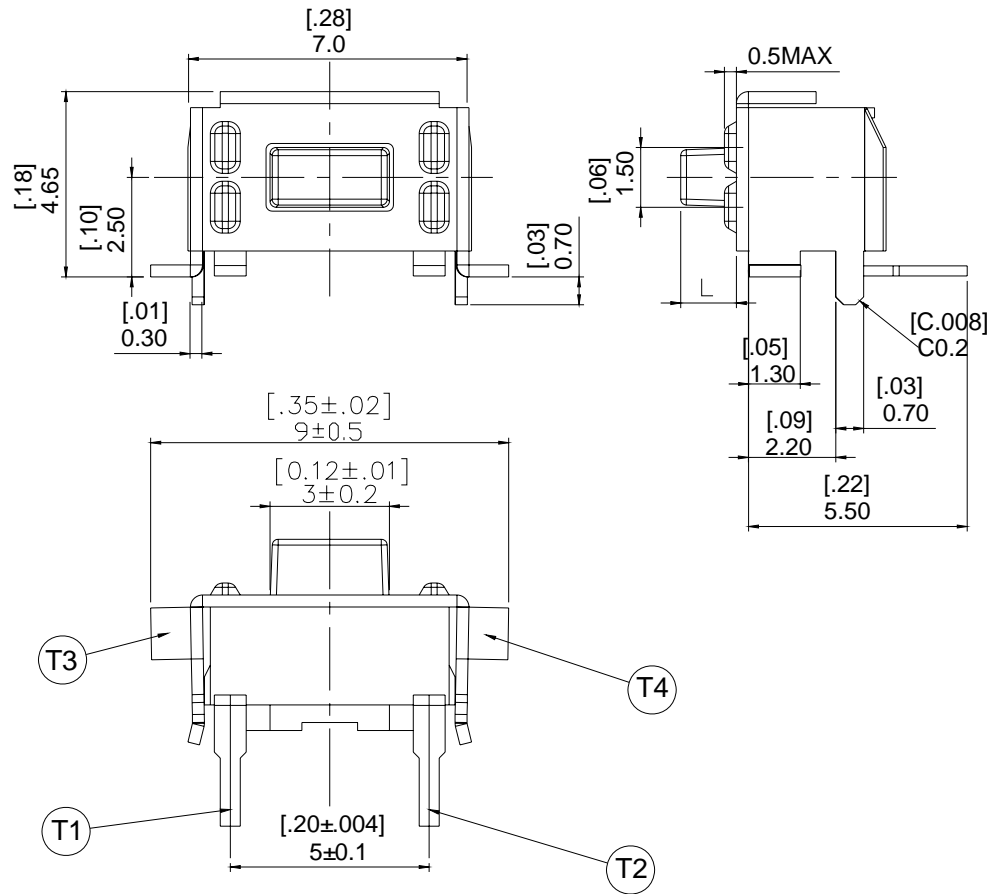
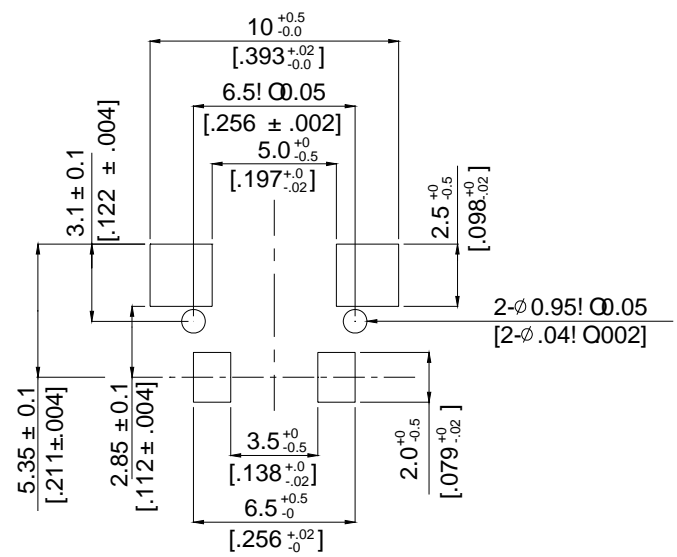

General Tolerance : ±0.2mm

HOW TO ORDER

TA □ □ - □ □ □ - V - □

Package:
T/R=Tape & Reel

Soldering:
V=Lead Free Solderable

Q=Halogen Free

Color of Stem for Operating Force:

W=White,160gf

N=Brown,160gf

S=Salmon,320gf

N/K=Black,160gf(TAC-35 Only)

L Height:

1=0.7mm

2=1.4mm

5=5.0mm

Prod. Size:

3=3.5X6

2=Ground Terminal on both side

C=Ground Terminal in the front

□=With Support Terminal(Only for TA2-3)

N=Without support Terminal (Only for TA2-3)

SPECIFICATION

△MECHANICAL

Operation Force: 320±50gf Salmon (S)
160±50gf White (W)

Stroke: 0.25 ^{+0.10mm}_{-0.20mm}

Operation Temperature: -25°C to +70°C

Storage Temperature: -30°C to +80°C

△ELECTRICAL

Electrical Life: 50,000 cycles for 160g, 320g.

Rating: 50mA, 12VDC

Contact Resistance: 100mΩ max.

Insulation Resistance: 100MΩ min. 500V DC

Dielectric Strength: 250VAC / 1 minute

Contact Arrangement 1 pole 1 throw.

MATERIAL

△Cover: Nickel silver.

△BASE: UL94V-0 Nylon High-Thermoplastic.

Color: Black

△CONTACT: Stainless with silver cladding.

△TERMINAL: Brass with silver plated.

△STEM: UL94V-0 Nylon High-Thermoplastic.

Color: Salmon(320gf), Brown(160gf)

SOLDERING PROCESS

△HAND SOLDERING: Use a soldering iron of 30 watts, controlled at 350°C approximately Max 5 seconds while applying.

△REFLOW SOLDERING : When applying reflow soldering, the peak temperature of the reflow oven should be set to 260°C max.

△CONDITION FOR SOLDERING : Reflow & non-washable type

△Temperature Profile :

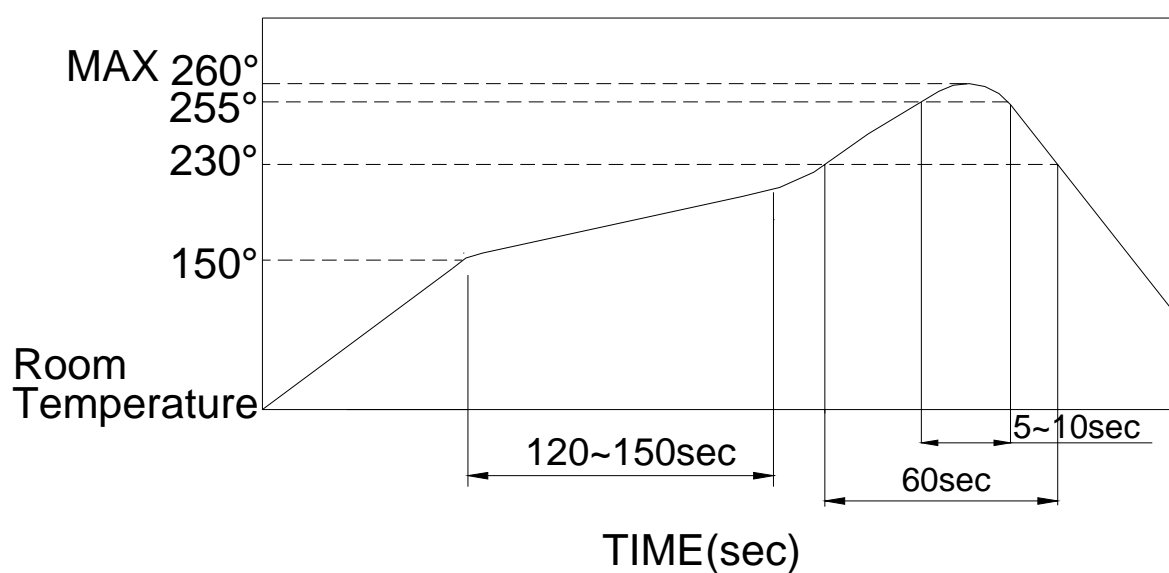

PACKING

Part Number	Number Per Reel
TAC-3	900
TA□2-3	

TAC-3 REEL

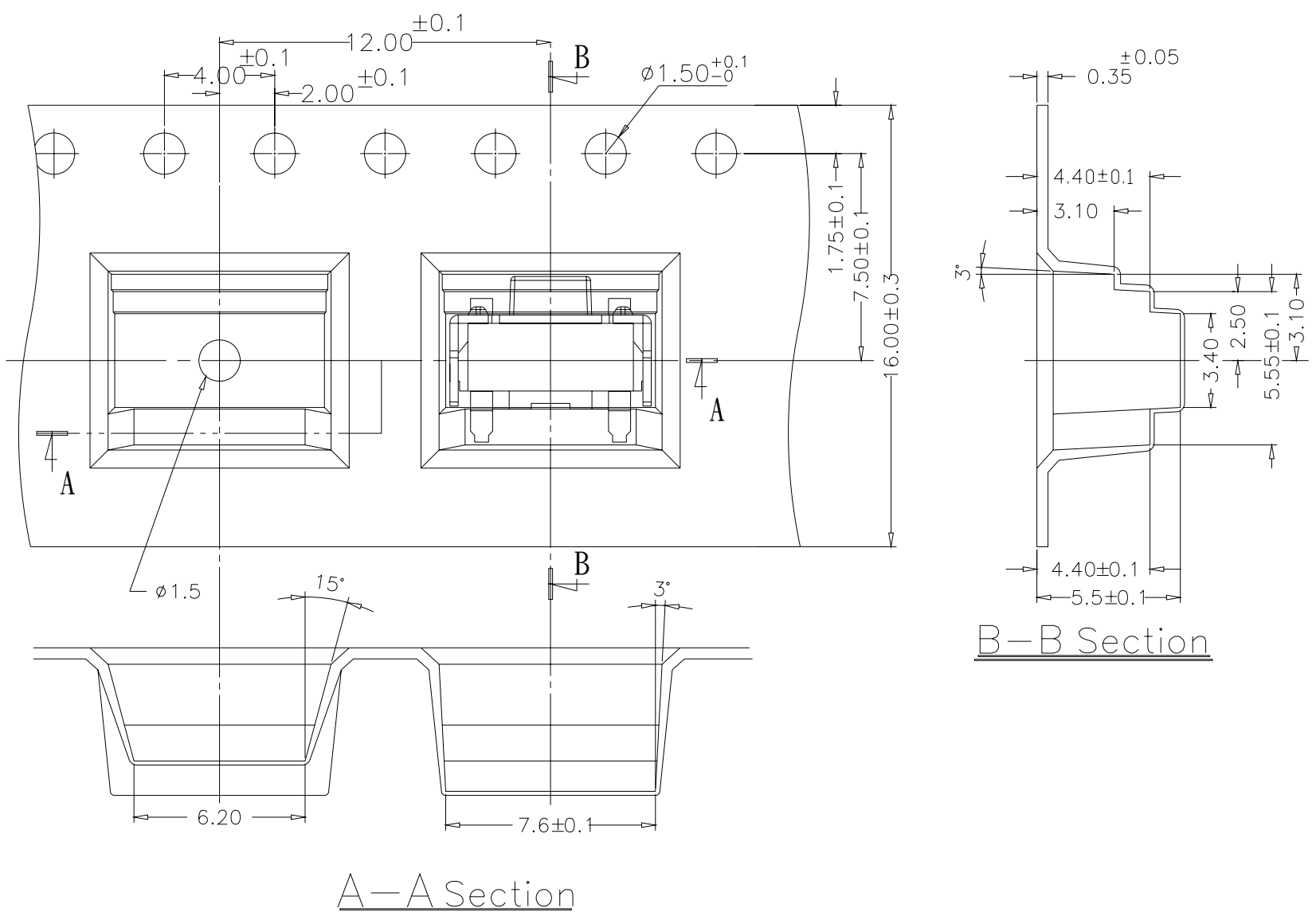

General Tolerance : $\pm 0.1\text{mm}$

TA□2-3 REEL

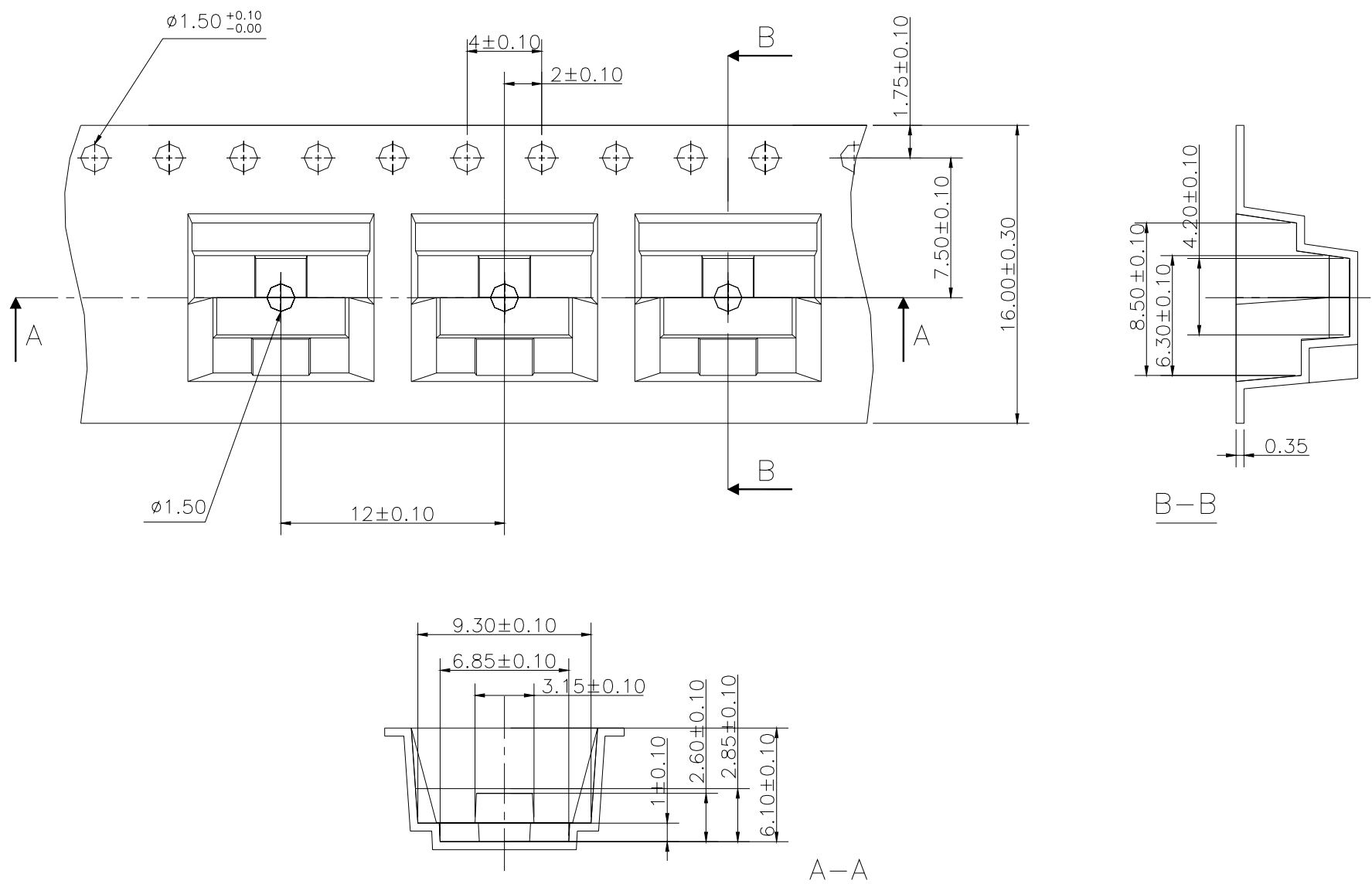

General Tolerance : $\pm 0.1\text{mm}$