



DIPTRONICS MANUFACTURING INC.

Speed & Technique

TE-MR SERIES



DIMENSIONS

TE-MRR

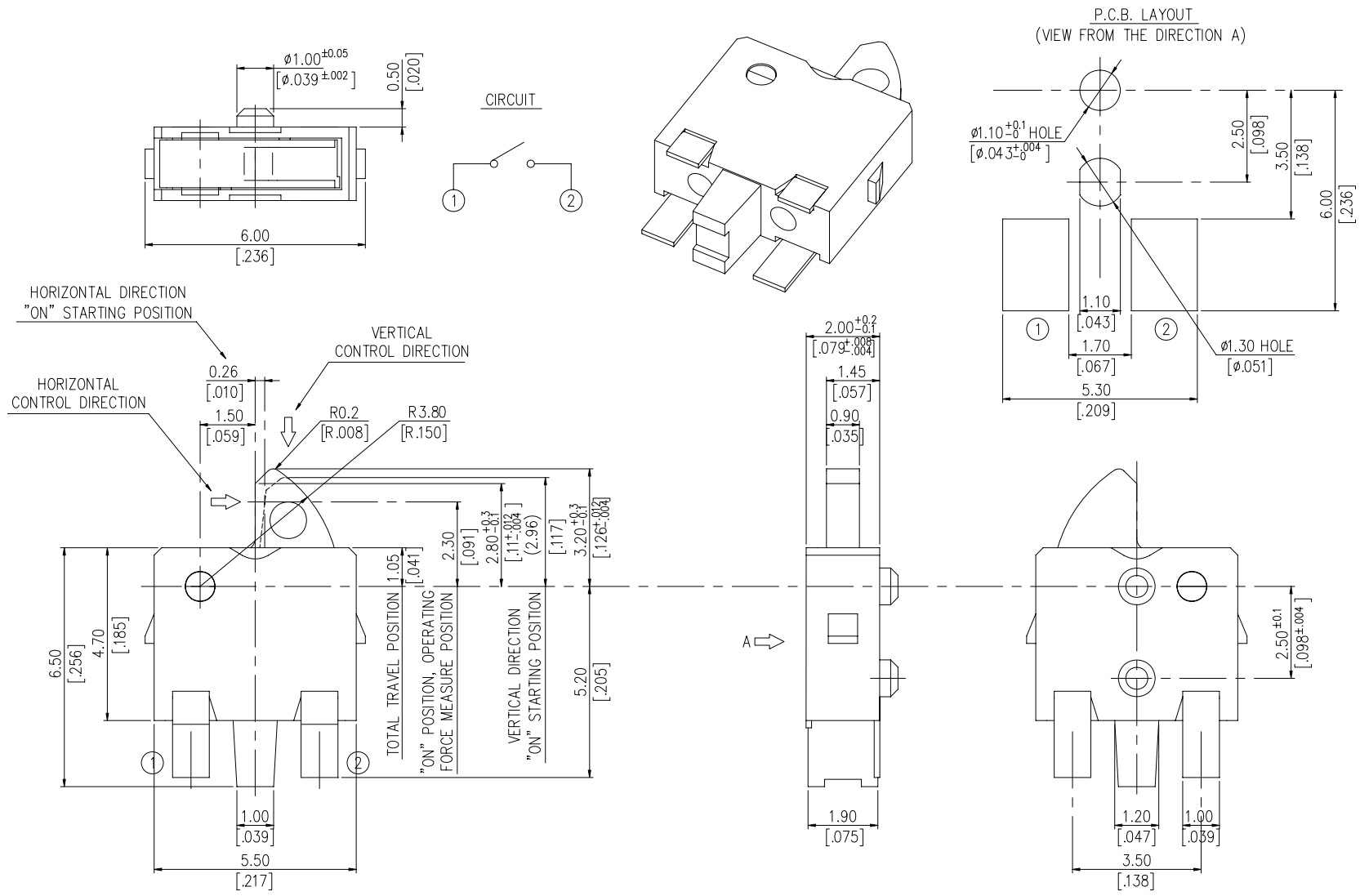

General Tolerance : $\pm 0.2\text{mm}$

TE-MRL

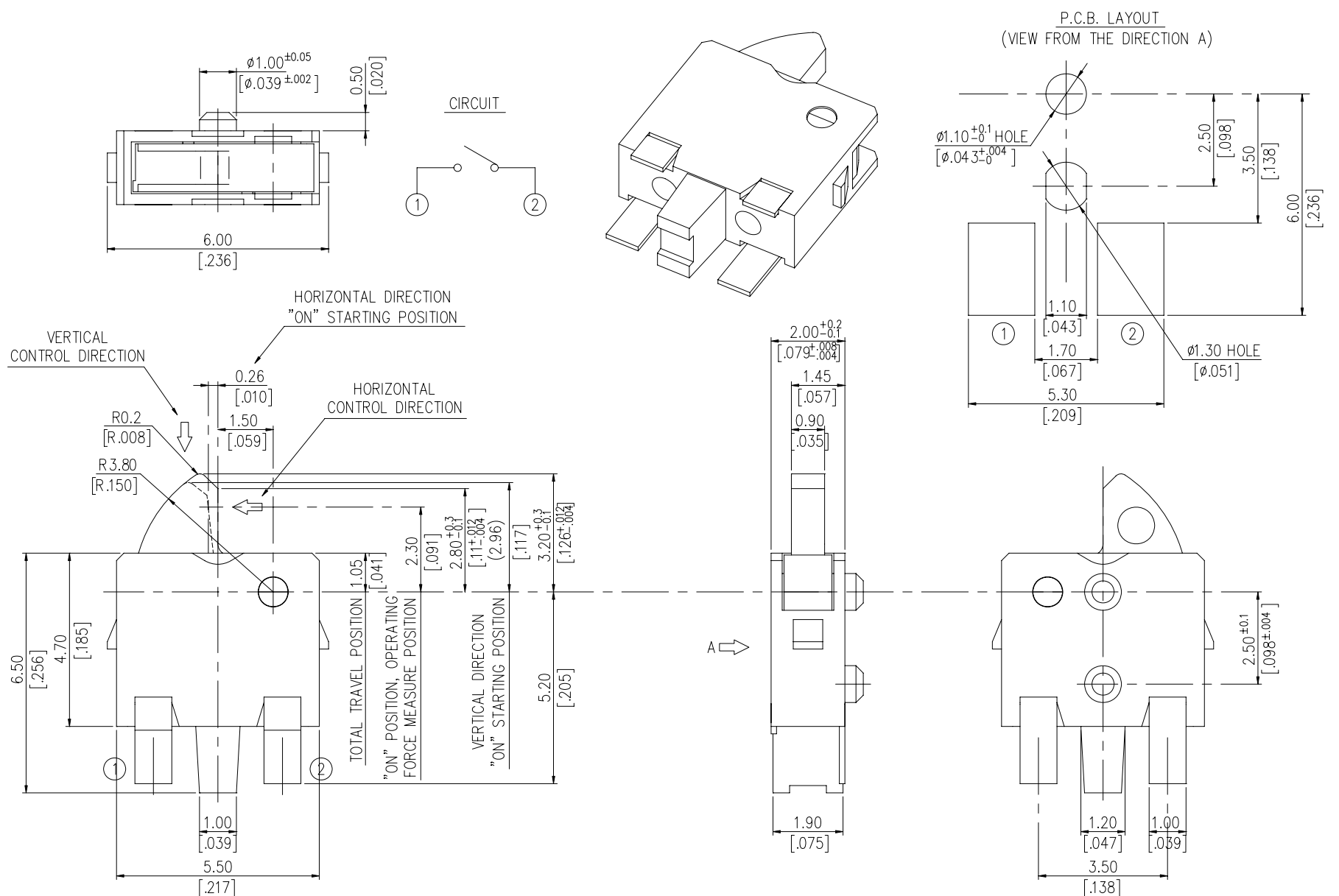

General Tolerance : $\pm 0.20\text{mm}$

TE-MRRC

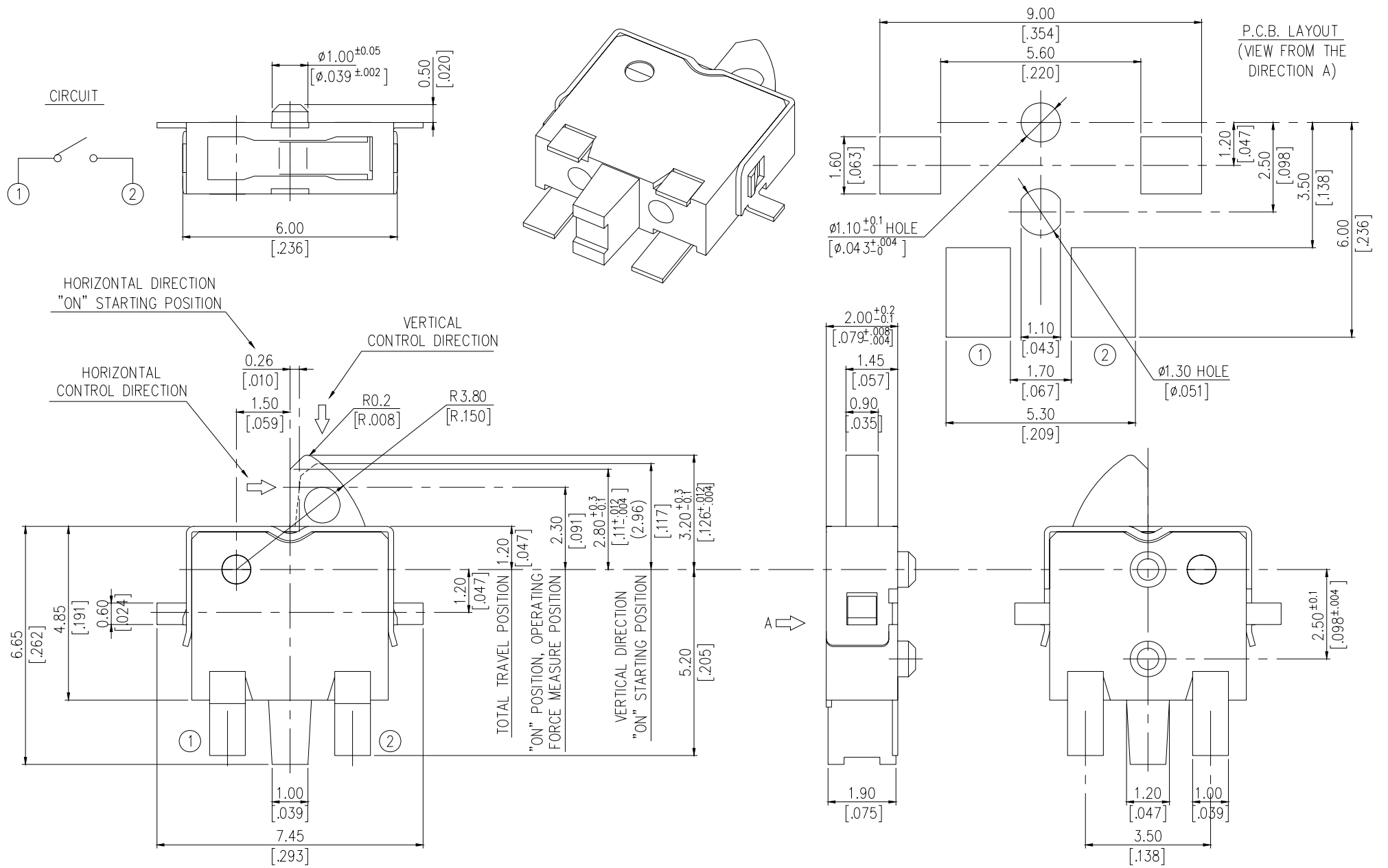

General Tolerance : $\pm 0.2\text{mm}$

TE-MRLC

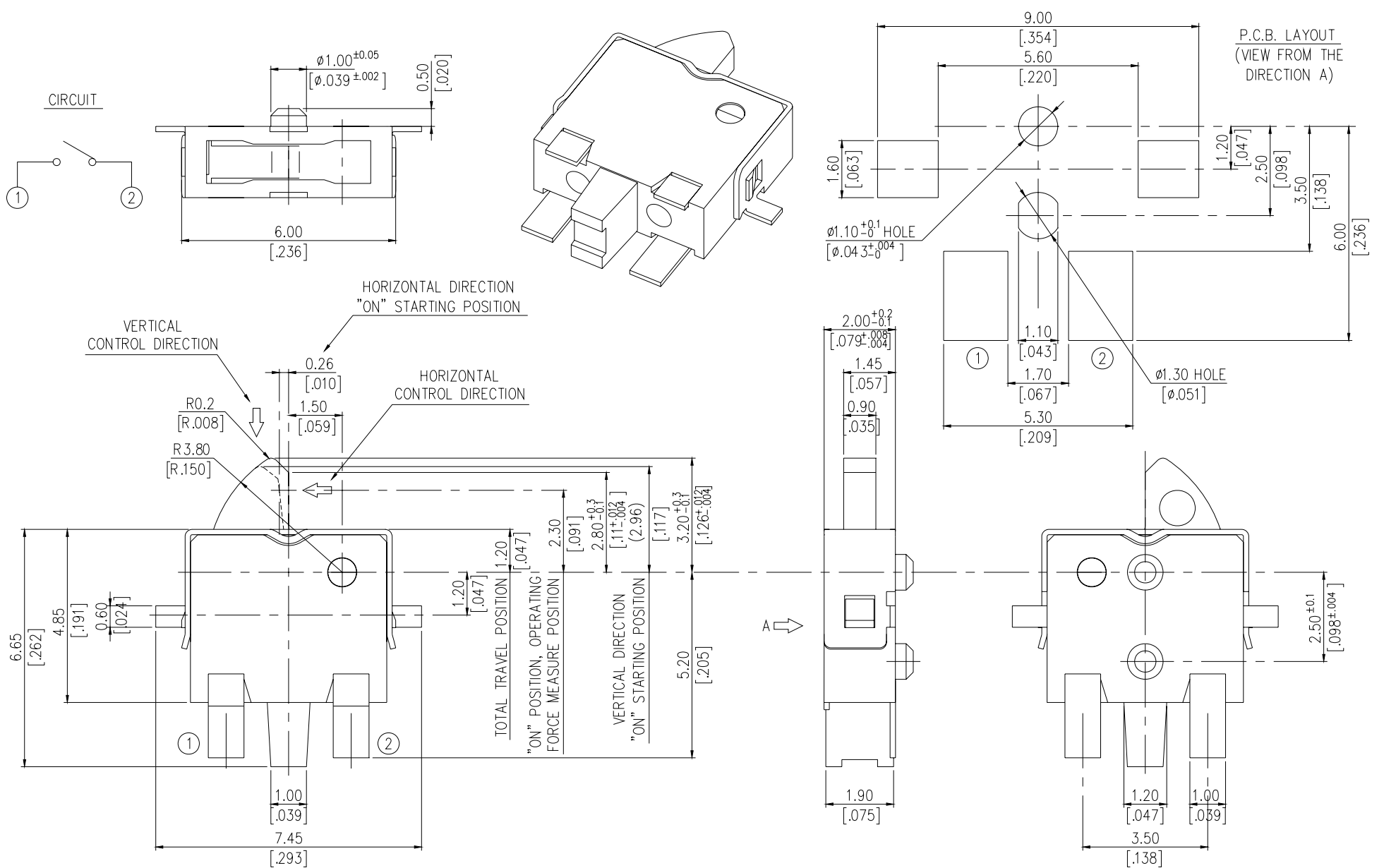

General Tolerance : $\pm 0.20\text{mm}$

HOW TO ORDER

TE - M R - -

Package :
T/R = Tape & Reel

Soldering :
V = Lead Free Solderable

Ground Terminal :
 = Without Ground Terminal
C = With Ground Terminal

Operating Direction :
R = Right Side
L = Left Side

Actuator Direction :
R = Side Stem

Terminal Type :
M = S.M.T Type

Detector Switch

SPECIFICATION

△MECHANICAL

Operation Force: 40gf max.

Stroke: 2.15mm max.

Operation Temperature: -10°C to +60°C

Storage Temperature: -20°C to +70°C

△ELECTRICAL

Electrical Life: 100,000 cycles

Rating: 50mA, 20VDC

Contact Resistance: 1Ω max.

Insulation Resistance: 100MΩ min. at 100VDC

Dielectric Strength: 100VAC/1 minute

Contact Arrangement: 1pole 1throw

MATERIAL

△COVER: Copper alloy, tin plated

△BASE: UL 94V-0 High-temp thermoplastic
Color: Black

△STEM: UL 94V-0 High-temp thermoplastic
Color: Black

△CONTACT DISC: Stainless with silver cladding

△TERMINAL: Brass with silver plated

SOLDERING PROCESS

For best results, please follow these recommendations : △Reflow Temperature Profile:

△HAND SOLDERING : Use a soldering iron of 30 watts,
Controlled at 608°F(320°C) approximately 2 seconds while
applying.

△REFLOW SOLDERING : When applying reflow soldering,
the peak temperature or the reflow oven should be set to
260°C max.

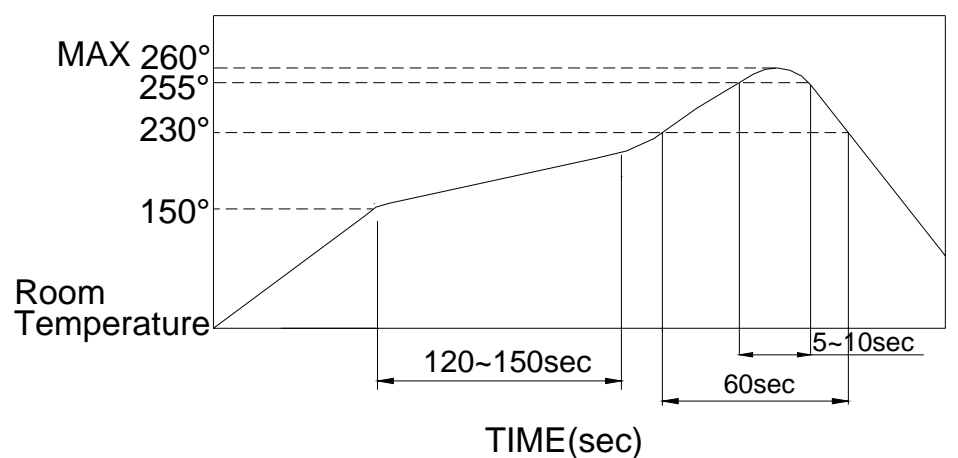

PACKING

Part Number	Number Per Tube	Number Per Reel
TE-MR□		3000
TE-MR□C		2000

TE-MR□ Reel

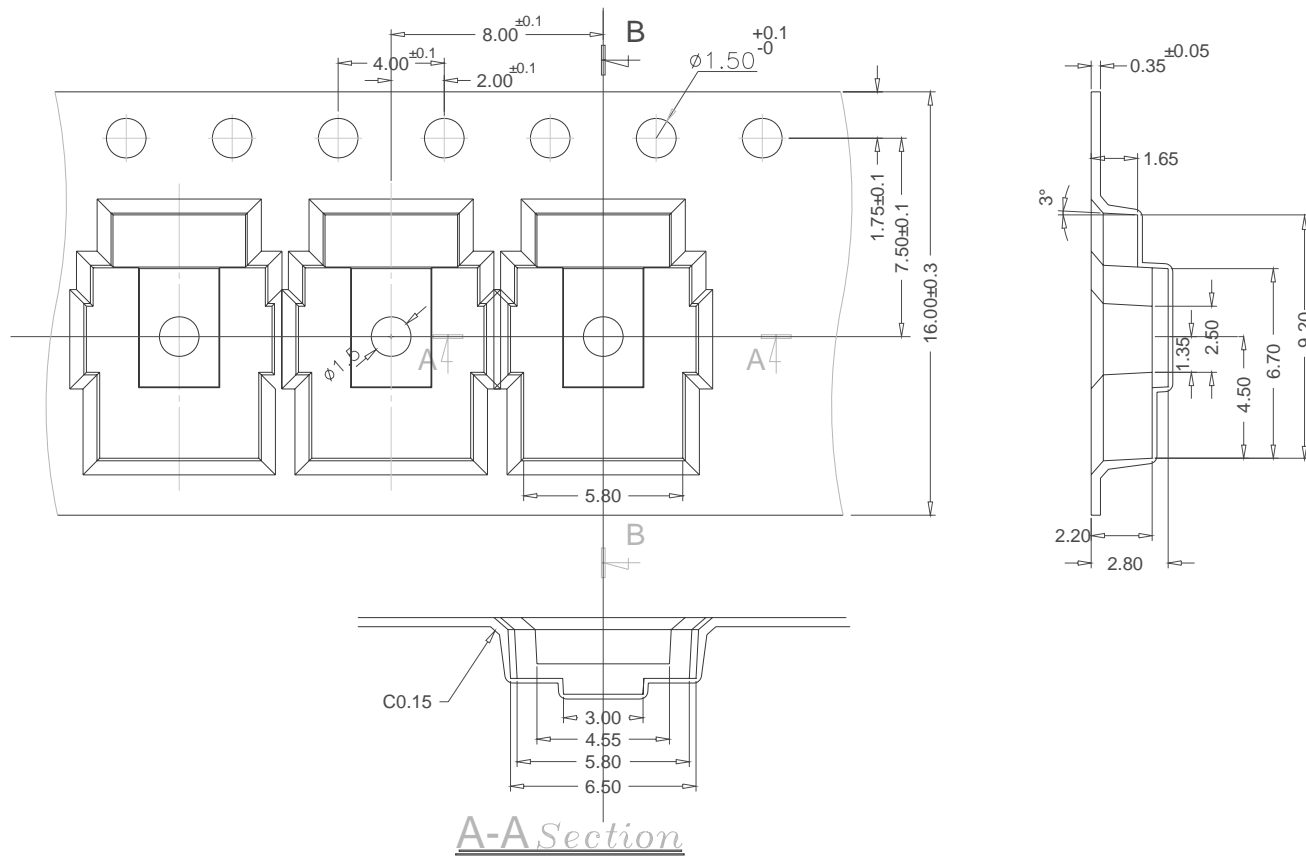

General Tolerance : ±0.1mm

TE-MR□C Reel

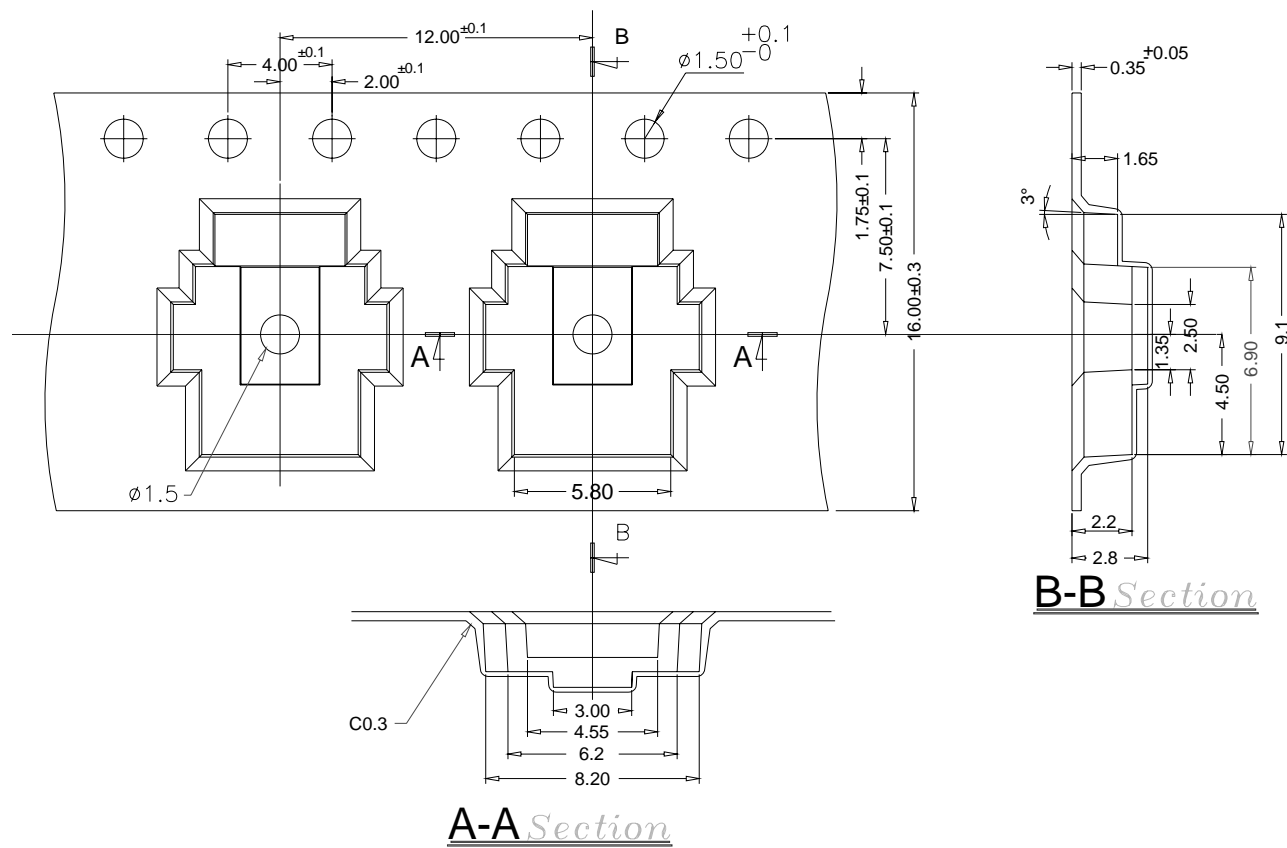

General Tolerance : ±0.1mm