

**DIMENSION**

**ZSSF-100**

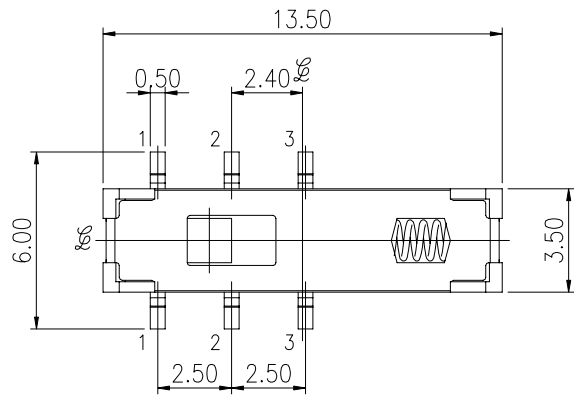

CIRCUIT DIAGRAM

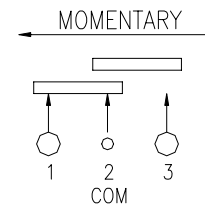

P.C.B. LAYOUT

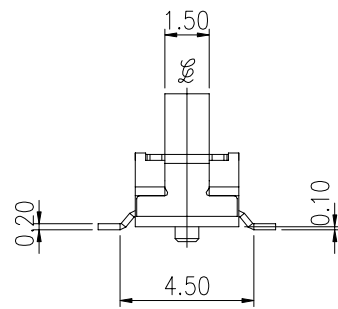
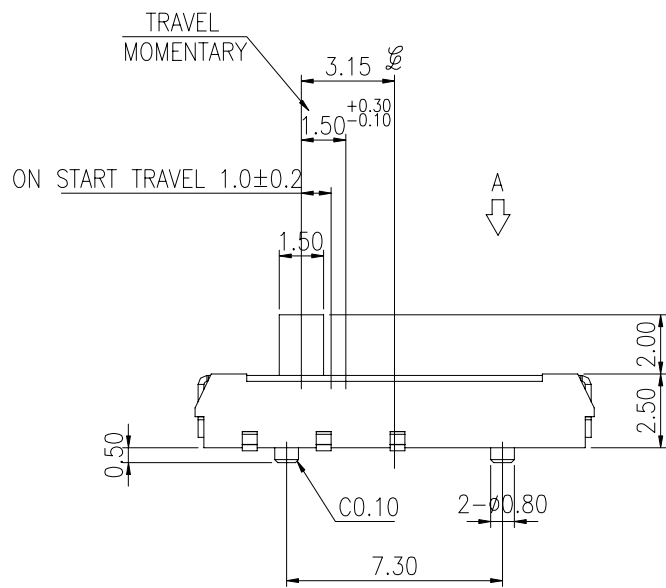
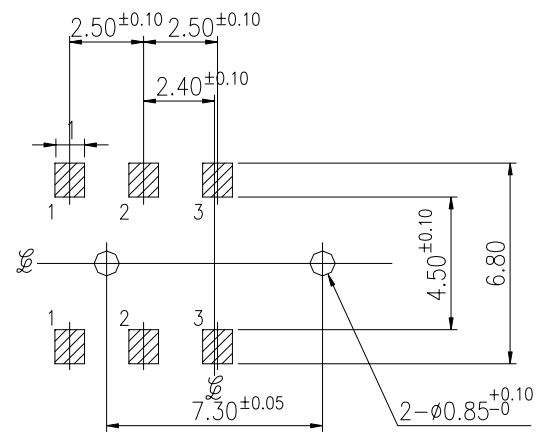

VIEW FROM THE DIRECTION A

General Tolerance : ±0.2mm

**ZSSF-200**

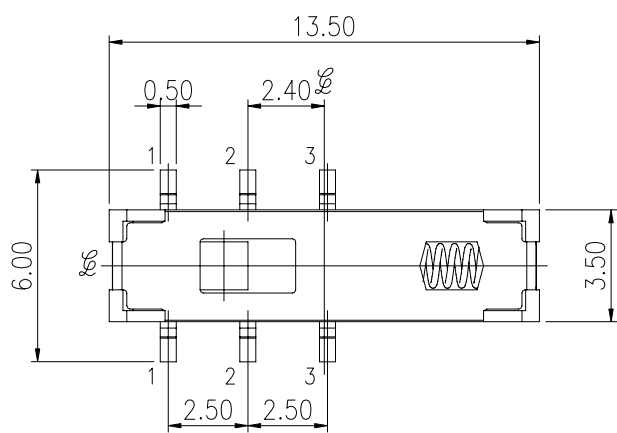

CIRCUIT DIAGRAM

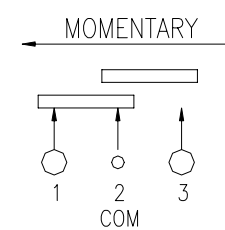

P.C.B. LAYOUT

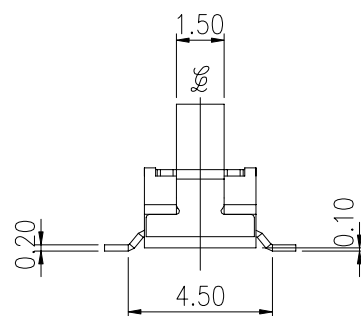
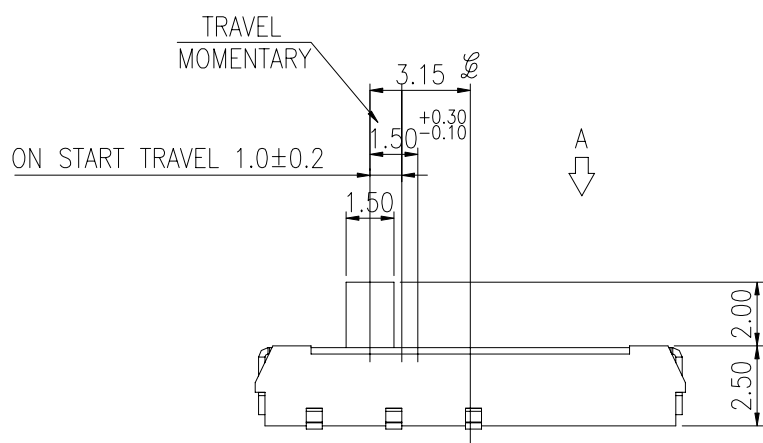
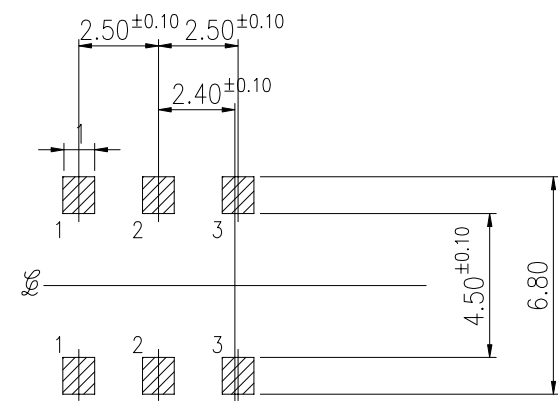

VIEW FROM THE DIRECTION A

General Tolerance : ±0.2mm

# ZSSG-101

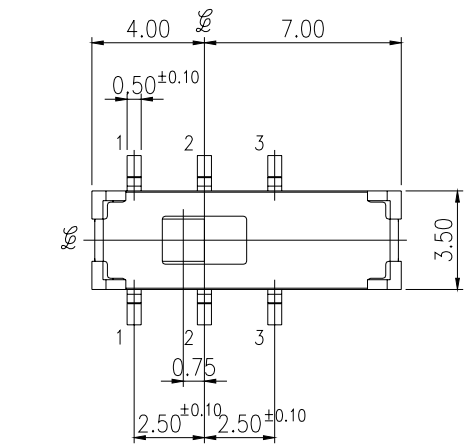

CIRCUIT DIAGRAM

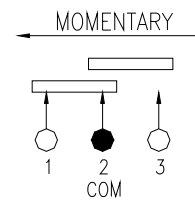

P.C.B. LAYOUT

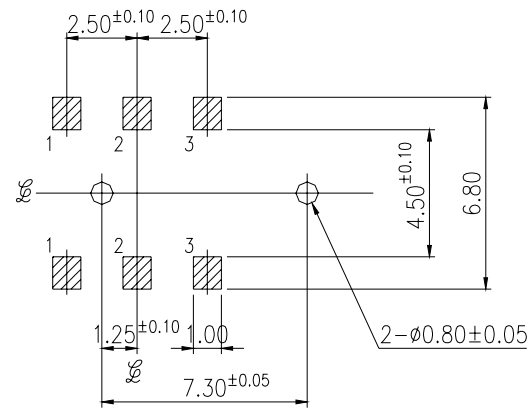

VIEW FROM THE DIRECTION A

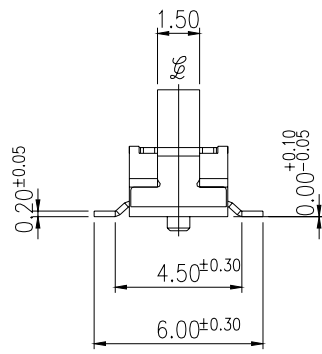
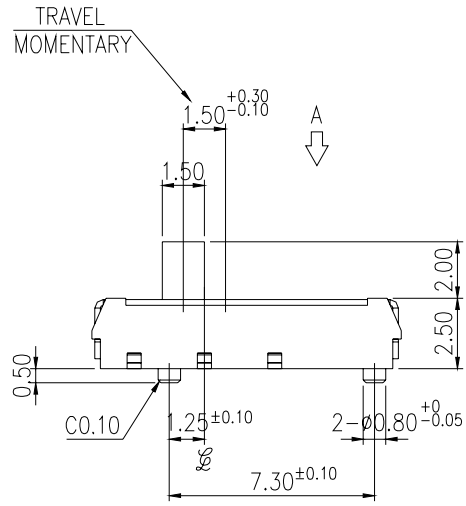

General Tolerance :  $\pm 0.2\text{mm}$

## HOW TO ORDER

Z S S  -  0  -  - T/R

Package Style :  
Tape & Reel

V = Lead Free Solderable  
Q = Halogen Free(ZSSG Only)

0 = 170g  
1 = 130g

1 = With Post  
2 = Without Post

Housing Length:  
F = 13.5mm  
G = 11.0mm

Slide

## SPECIFICATION

### △MECHANICAL

Operation Force: 80gf min, 220gf max

Stroke : 1.5mm

Operation Temp: -20°C to +70°C

Storage Temp: -40°C to +85°C

### △ELECTRICAL

Electrical Life: 25,000 cycles

Rating: 100mA, 12VDC

Contact Resistance: 100mΩ max.

Insulation Resistance: 100MΩ min. (100VDC)

Dielectric Strength: 100VAC/ 1minute

Circuit: 1P2T

## MATERIAL

△COVER: Stainless steel

△BASE: UL 94V-0 High-Temp thermoplastic

Color: Black

△ACTUATOR: UL 94V-0 High-Temp thermoplastic

Color: Black

△CONTACT: Brass with silver plated

△TERMINAL: Brass with silver plated

△SPRING: Stainless steel

## SOLDERING PROCESS

△ HAND SOLDERING : Use a soldering iron of 30 watts, controlled at 350°C approximately 5 seconds while applying.

△ WAVE SOLDERING : Recommended solder temperature at 500°F(260°C)max. 5 seconds for through Hole type.

△ REFLOW SOLDERING : When applying reflow soldering, the peak temperature or the reflow oven should be set to 260°C max.

△ Temperature Profile :

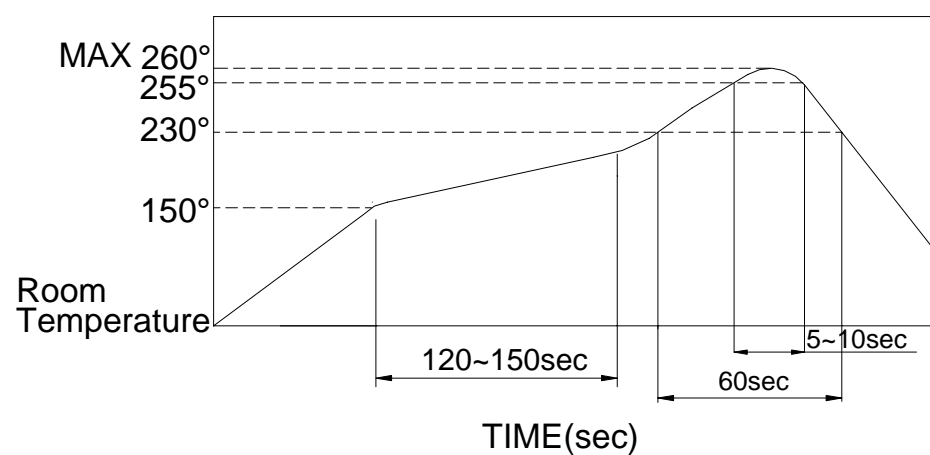

## PACKING

### ZSS CARRIER

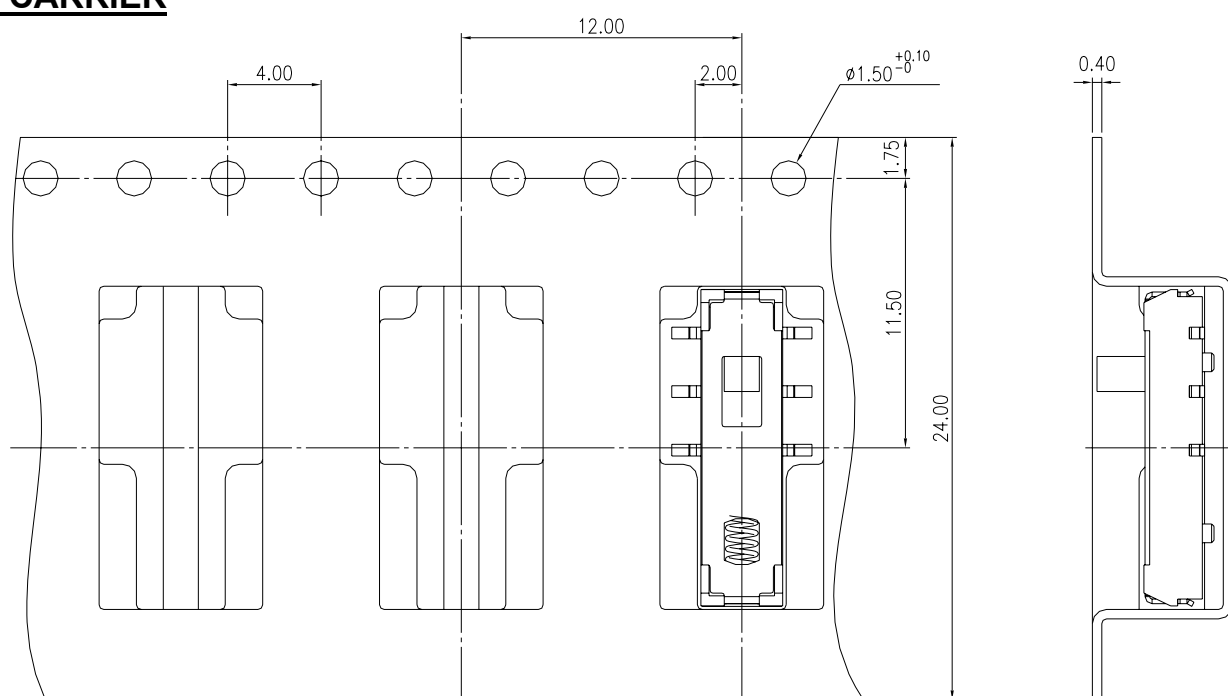

Part Number	Number Per Reel	Number Per Tube
ZSS	1000	