



DIPTRONICS MANUFACTURING INC.

M2D SERIES



DIMENSIONS

M2D

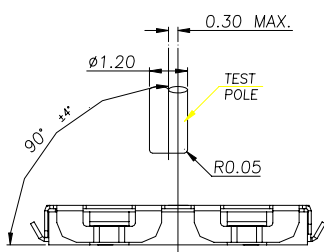
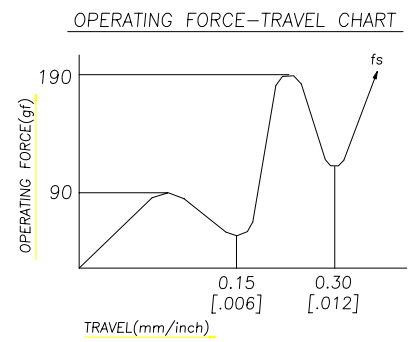
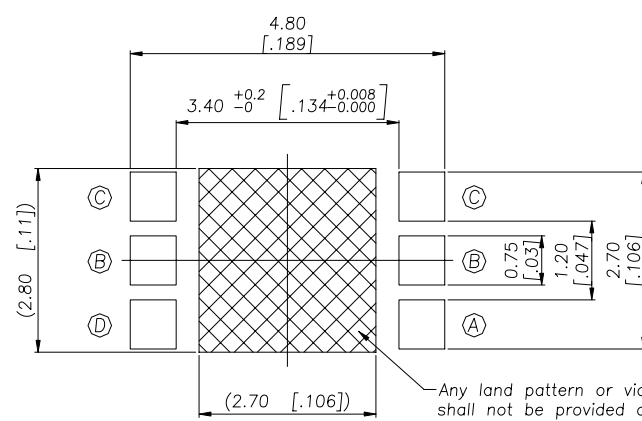
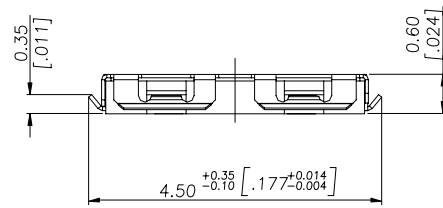
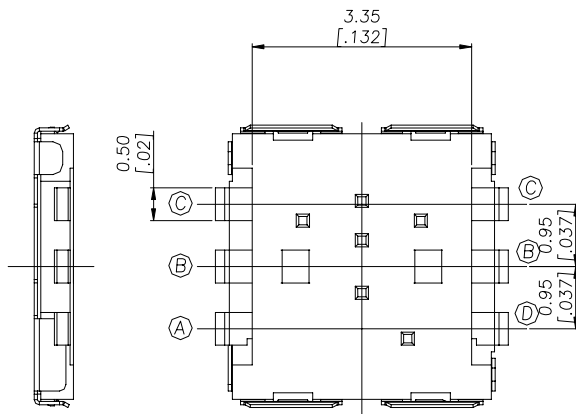
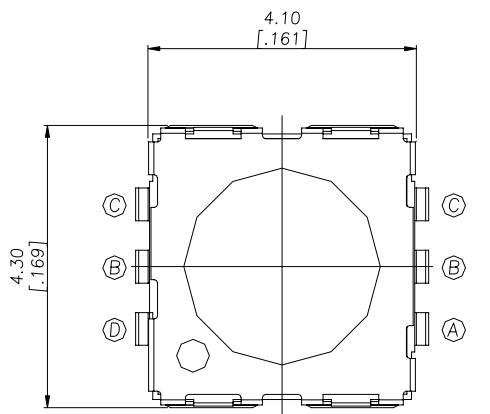

RECOMMENDED OPERATING CONDITIONS

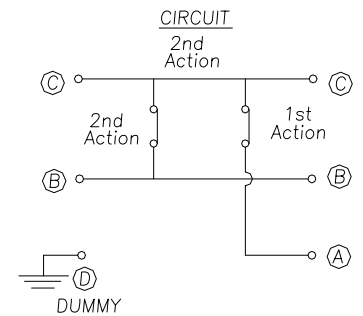
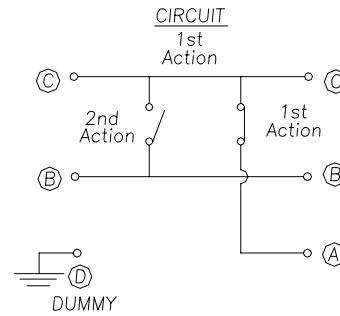
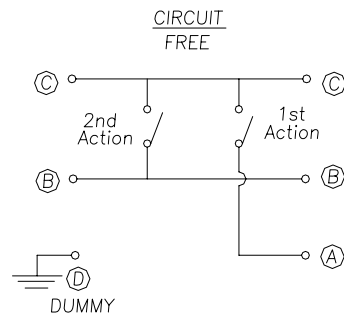

Any land pattern or vias shall not be provided at 3.4x2.8 area.

GENERAL TOLERANCES MAX:±0.2mm.

HOW TO ORDER

M2DL - Q - □

- Package :
- T/R=Tape & Reel
- Halogen Free
- J Terminal SMT Type
- Miniature Double

SPECIFICATION

△ MECHANICAL

Mechanical Life : 100,000 cycles.

Operation Force : 1st 90±40gf
2nd 190±60gf

Stroke : 1st 0.15±0.10mm
2nd 0.30±0.15mm

Operation Temperature Range : -20°C to +70°C

Storage Temperature Range : -40°C to +85°C

△ ELECTRICAL

Electrical Life : 100,000 cycles

Switching Rating : 50mA,12VDC

Contact Resistance: 500mΩ max.

Insulation Resistance: 100MΩ min. at 100VDC

Dielectric Strength: 250VAC/1 minute

Contact Arrangement: 1 pole 2 throw

MATERIAL

△ Terminal : Phosphor Bronze, With Silver Plating

△ Base : High-Temp Thermoplastic LCP UL 94V-0
Color : Black

△ Tape : Kapton

△ Cover : Stainless Steel

△ CONTACT DISC: Stainless with silver cladding

SOLDERING PROCESS

△ HAND SOLDERING: Use a soldering iron of 30 watts, controlled at 350°C approximately 5 seconds.

△ REFLOW SOLDERING: When applying reflow soldering, the peak temperature or the reflow oven should be set at 260°C max.

△ Any flux enters the switch may fail the conductivity.

△ Reflow Temperature Profile: (reference)

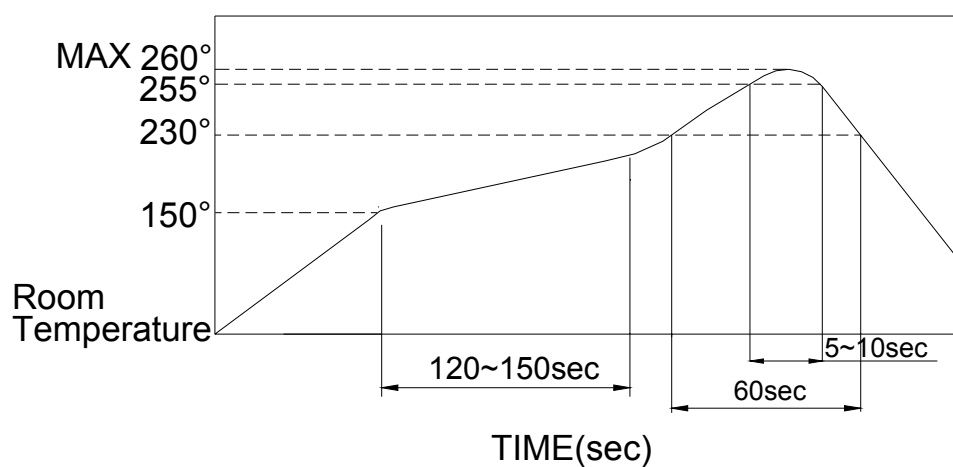

PACKING

M2D CARRIER

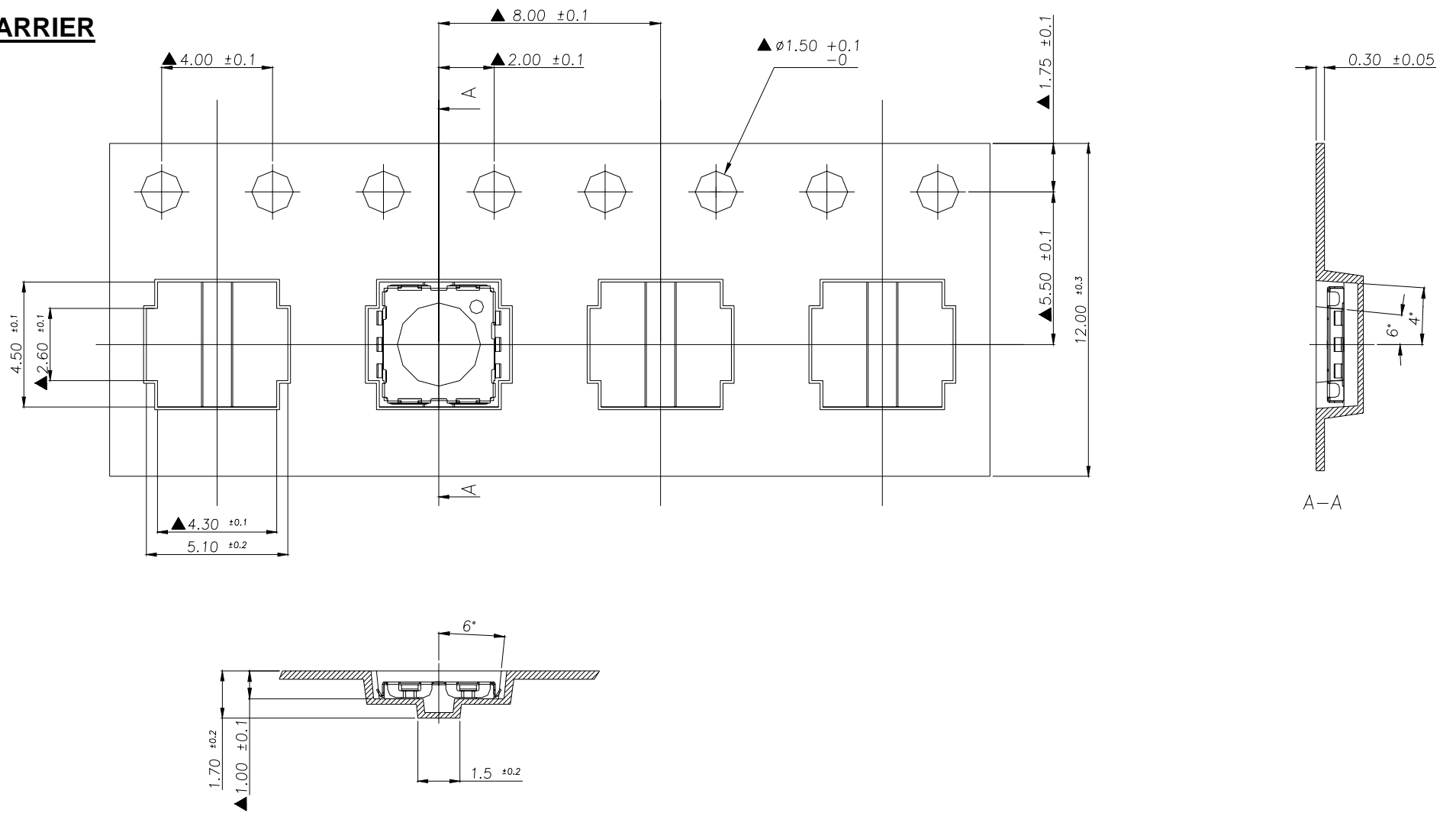

****GENERAL TOLERANCES MAX:±0.1mm.****

Part Number	Number Per Tube	Number Per Reel
M2D		

****To be confirmed**