

**FEATURES**

- ※ J or M terminations
- ※ Long Travel type
- ※ Long operating cycles
- ※ IP67

**APPLICATION**

- ※ Automotive
- ※ Industrial electronics
- ※ Network infrastructure and IT
- ※ Elevator

**SPECIFICATION**

Contact Rating	20mV DC~32V DC/1.0 mA~50 mA
Contact Resistance	100mΩ max.
Insulation Resistance	10MΩ min. 100V DC
Dielectric Strength	250V AC/1 minute
Operating Force	160±50gf, Brown(N) 200±50gf, Red(R) 350±100gf, Salmon(S)
Travel	0.3mm (160gf) 0.35mm (200gf) 0.5mm (350gf)
Operating Life	300,000 cycles (350gf) 500,000 cycles (200gf) 5,000,000 cycles (160gf)
Operating Temp.	-40°C ~ +85°C
Storage Temp.	-55°C(10 days) ~ +85°C(4 days)

**HOW TO ORDER**

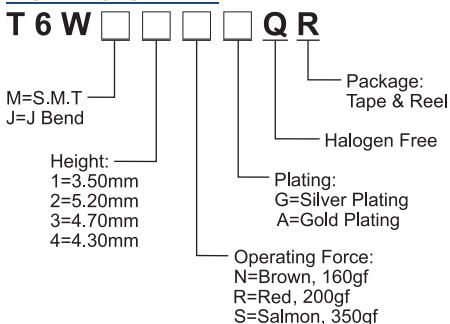

**CIRCUIT**

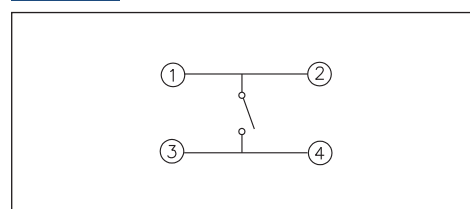

**PACKAGE**

<Tape & Reel>  
T6W  1: 2000 pcs  
T6W  2, 3, 4: 1000 pcs

TACT SWITCH

**T6WM**

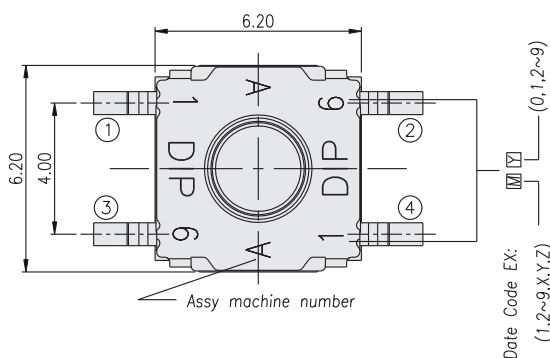

PART NO.	A	H
T6WM1	ø2.90	3.50
T6WM2	ø2.70	5.20
T6WM3	ø2.70	4.70
T6WM4	ø2.70	4.30

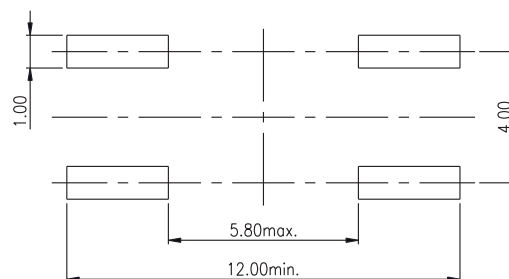
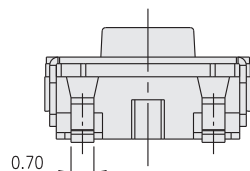
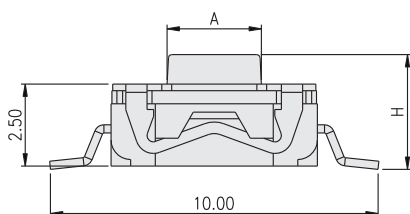

P.C.B. LAYOUT

T6WJ

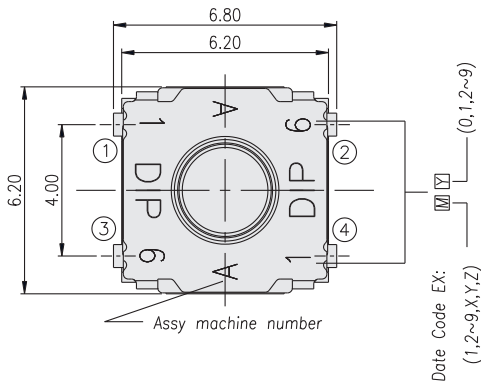

PART NO.	A	H
T6WJ1	ø2.90	3.50
T6WJ2	ø2.70	5.20
T6WJ3	ø2.70	4.70
T6WJ4	ø2.70	4.30

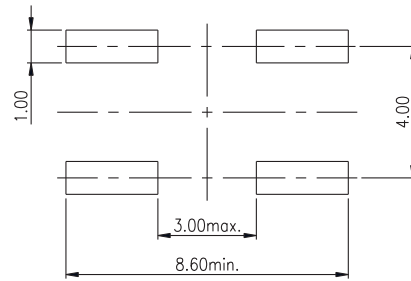
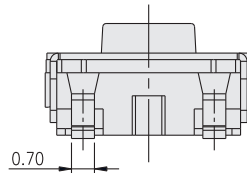
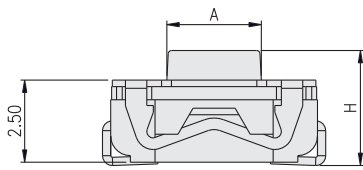

P.C.B. LAYOUT