

ILLUMINATED SWITCH ML9 SERIES

**Tact Switch
Illuminated**

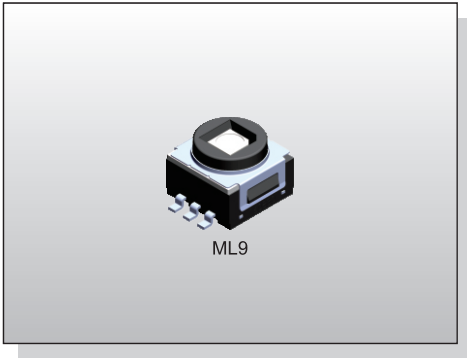

ILLUMINATED SWITCH



FEATURES

- ※ Various LED options
- ※ 300,000 operating life cycles

APPLICATION

- ※ Automotive
- ※ Network equipment
- ※ Telecommunications
- ※ Medical equipment
- ※ Industrial controls

SPECIFICATION

Contact Rating	50mA, 32V DC
Contact Resistance	100mΩ max.
Insulation Resistance	100MΩ min. 100V DC
Dielectric Strength	250V AC/1 minute
Operating Force	400±100gf
Travel	0.45mm
Operating Life	300,000 cycles
Operating Temp.	-40°C ~ +85°C
Storage Temp.	-40°C ~ +85°C

CIRCUIT

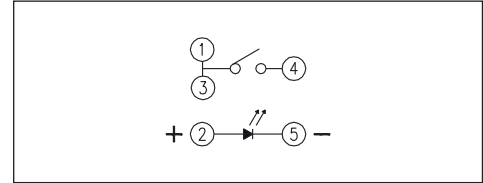

PACKAGE

<Tape & Reel>
650 pcs.

HOW TO ORDER

ML9 - M **QR**

- S.M.T.
- Without Post
- With Post
- Operating Force: 4=400gf
- LED Color:
 - Without LED
 - B=Blue
 - G=Green
 - R=Red
 - W=White
 - Y=Yellow
 - A=Amber
- Package: Tape & Reel
- Halogen Free

ML9

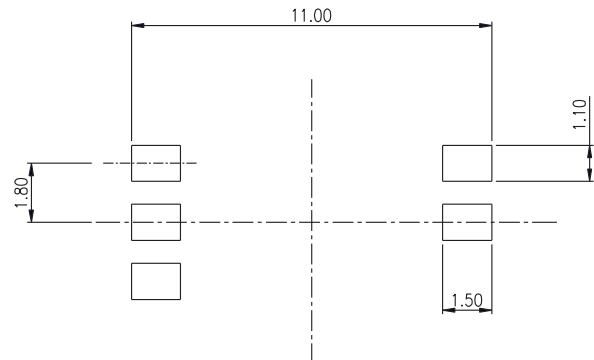
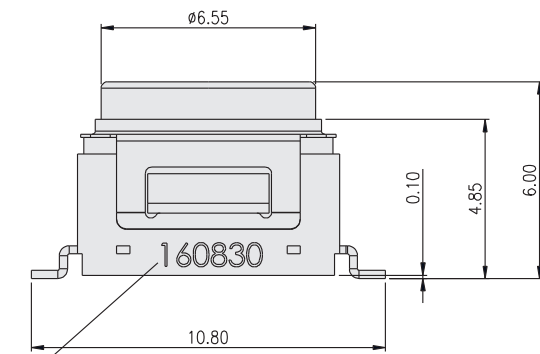
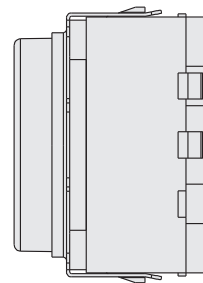
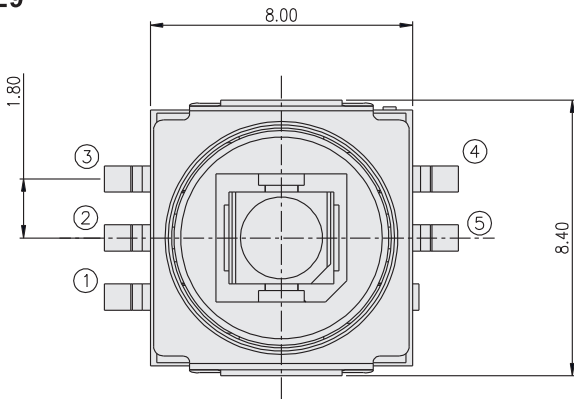

P.C.B. LAYOUT

Date code: YYMMDD